

GENERAL INFORMATION

AC200+ (Threaded Rod Anchors)

Hybrid Acrylic Injection Adhesive Anchoring System

PRODUCT DESCRIPTION

The AC200+ is a two-component, high strength adhesive anchoring system. The system includes injection adhesive in plastic cartridges, mixing nozzles, dispensing tools and cleaning equipment. The AC200+ is a high strength adhesive designed for various applications and hole drilling and cleaning techniques. It is also very suitable for bonding rebars to concrete as post-installed reinforcement application.

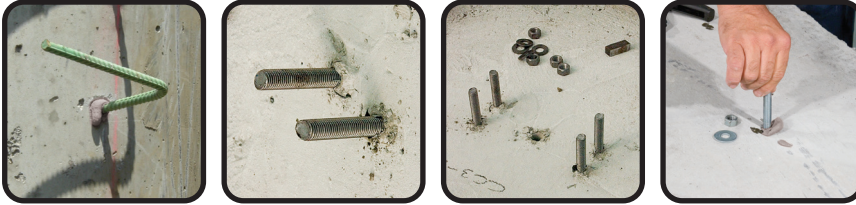

GENERAL APPLICATIONS AND USES

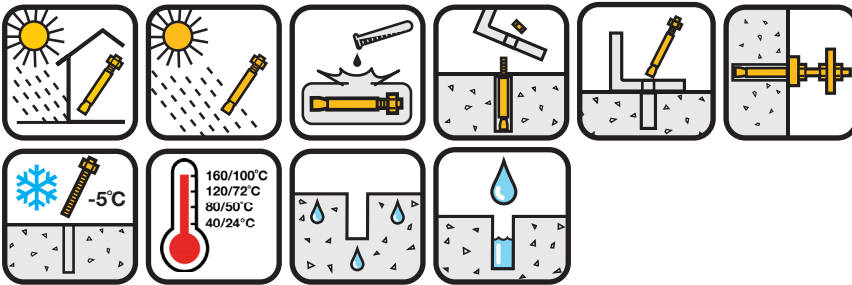

FEATURES AND BENEFITS

- Designed for use with threaded rod or reinforcing bar
- Consistent performance in cracked and uncracked concrete of variable strength
- Wide range of steel element diameter and embedment depth
- Flexible fixture thicknesses
- Simple installation and low cleaning effort
- Versatile low odour formula with quick curing time
- Wide range of ambient temperatures, very high maximum service temperature
- Cartridge design allows multiple uses using extra mixing nozzels

APPROVALS AND LISTINGS



*Please refer to Fire Test Report for load capacities under fire.

LOADING CONDITIONS

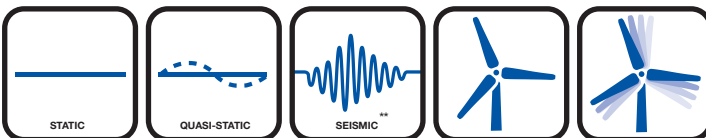

**Please refer to the relevant ETA for capacities for seismic design. The capacities in this document are for static / quasi-static loads.

SUITABLE BASE MATERIALS

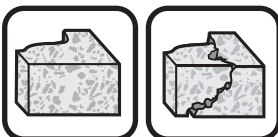

SYSTEM COMPONENTS



AC200+ Hybrid Acrylic

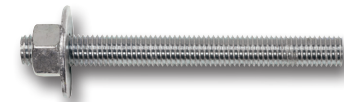

Threaded Rod

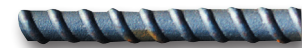

Reinforcing Bar

GRADES

- Carbon Steel 4.6, 4.8, 5.6, 5.8, 8.8
- Stainless Steel A2, A4
- High Corrosion Resistance Steel HCR
- Rebar $f_y = 400$ to 600 MPa

APPROVALS

- ETA-16/0905
- ESR-4027

ADHESIVE ANCHORS

AC200+ CONCRETE ANCHORING SYSTEM



Real-Time Anchor Design Software
anchors.dewalt.com/anchors/
tech-support-software/
dewalt_design_assist.php

INSTALLATION INFORMATION

INSTALLATION DATA - THREADED ROD

	Notation	Unit	AC200+ - Threaded rod							
			M8	M10	M12	M16	M20	M24	M27	M30
Nominal diameter of element	d_{nom}	[mm]	8	10	12	16	20	24	27	30
Nominal drill bit diameter	d_0	[mm]	10	12	14	18	22	28	32	35
Diameter of hole clearance in fixture: Preset installation	d_f	[mm]	9	12	14	18	22	26	30	33
Diameter of hole clearance in fixture: Through installation	d_f	[mm]	12	14	16	20	24	30	33	40
Diameter of steel brush	d_b	[mm]	11.5	13.5	15.5	20.0	24.0	30.0	31.8	37.0
Minimum embedment and drill hole depth	$h_{ef,min} = h_1$	[mm]	60	60	70	80	90	96	108	120
Maximum embedment and drill hole depth	$h_{ef,max} = h_1$	[mm]	160	200	240	320	400	480	540	600
Minimum member thickness	h_{min}	[mm]	$h_{ef} + 30 \text{ mm} \geq 100 \text{ mm}$				$h_{ef} + 2 \cdot d_0$			
Minimum spacing	s_{min}	[mm]	40	50	60	75	95	115	125	140
Minimum edge distance	c_{min}	[mm]	35	40	45	50	60	65	75	80
Thickness of fixture	t_{fix}	[mm]	$0 \text{ mm} \leq t_{fix} \leq 1500 \text{ mm}$							
Maximum torque moment	T_{max}	[Nm]	10	20	40 ¹⁾	60	100	170	250	300
Torque wrench socket size	S_w	[mm]	13	17	19	24	30	36	41	46

1) Maximum torque moment for M12 with steel grade 4.6 is 35 Nm

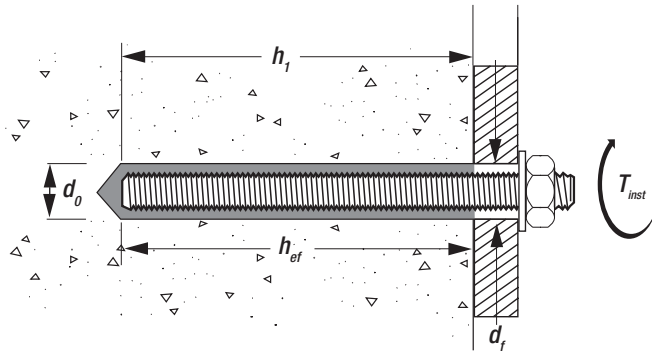

INSTALLATION DATA - REINFORCEMENT BAR

	Notation	Unit	AC200+ - Reinforcing bar										
			Ø8	Ø10	Ø12	Ø14	Ø16	Ø20	Ø24	Ø25	Ø28	Ø32	
Nominal diameter of element	d_{nom}	[mm]	8	10	12	14	16	20	24	25	28	32	
Nominal drill bit diameter	d_0	[mm]	10	12	14	16	18	20	25	30	32	35	40
Diameter of steel brush	d_b	[mm]	11.5	13.5	15.5	17.5	20.0	22.0	27.0	31.8	34.0	37.0	43.5
Minimum embedment and drill hole depth	$h_{ef,min} = h_1$	[mm]	60	60	70	75	80	90	96	100	112	128	
Maximum embedment and drill hole depth	$h_{ef,max} = h_1$	[mm]	160	200	240	280	320	400	480	500	560	640	
Minimum member thickness	h_{min}	[mm]	$h_{ef} + 30 \text{ mm} \geq 100 \text{ mm}$				$h_{ef} + 2 \cdot d_0$						
Minimum spacing	s_{min}	[mm]	40	50	60	70	75	95	120	120	130	150	
Minimum edge distance	c_{min}	[mm]	35	40	45	50	50	60	70	70	75	85	

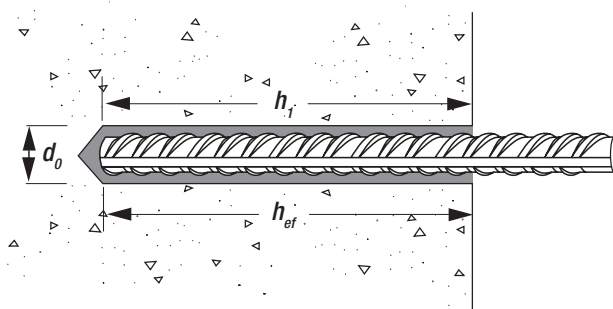

INSTALLATION INSTRUCTIONS

Manual Air Cleaning (MAC)

Cleaning for dry and wet bore hole with bore hole diameter $d_0 \leq 20$ mm and bore hole depth $h_0 \leq 10d_0$, uncracked concrete only

Compressed Air Cleaning (CAC)

Cleaning for dry, wet and water filled bore hole with all diameter and hole depth, uncracked and cracked concrete

Hollow Drill Bit (HDB)

Cleaning while drilling the hole using a hollow drill bit connected to a vacuum

Hollow Drill Bit (HDB)

Standard Drill Bit

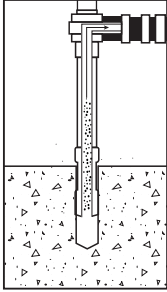

1a.) Connect the hollow drill bit of proper size to a vacuum, and drill a hole into the base material to the required depth while the vac is running. The dust is removed during the drilling process. Proceed with **Step 5**.

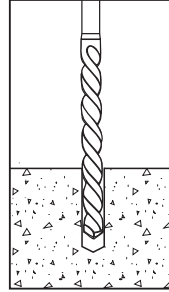

1b.) Using the proper drill bit size, drill a hole into the base material to the required depth.

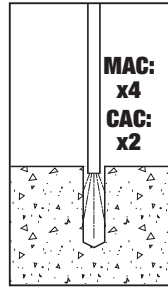

2.) Before cleaning, remove any standing water out of the drill hole.
Starting from the bottom of the hole, blow the hole clean with a hand pump minimum of 4 times (MAC) or with compressed air (min. 6 bar) minimum of 2 times (CAC).
If the bore hole ground cannot be reached, an extension must be used.

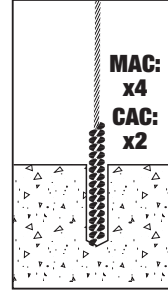

3.) Select a brush of the correct diameter. Starting from the hole ground, brush the hole a minimum of 4 times (MAC) or 2 times (CAC).
If the bore hole ground is not reached, a brush extension must be used.

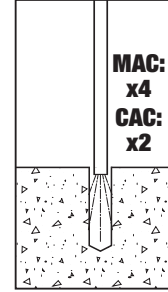

4.) Finally, blow the hole clean again with a hand pump minimum of 4 times (MAC) or with compressed air (min. 6 bar) minimum of 2 times (CAC).
If the bore hole ground cannot be reached, an extension must be used.

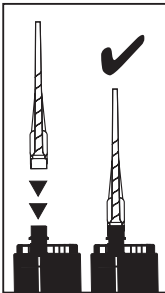

5.) Attach a supplied static-mixing nozzle to the cartridge and load the cartridge into the correct dispensing tool.

For foil tube type cartridges, cut off the foil tube clip before use.

For every working interruption longer than the recommended working time as well for new cartridges, a new mixer nozzle must be used.

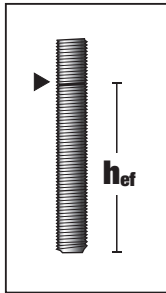

6.) Mark the required embedment depth on the anchor rod.

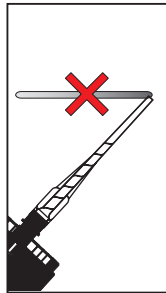

7.) Squeeze out a minimum of 3 full strokes and discard non-uniformly mixed adhesive until the mortar shows a consistent colour.

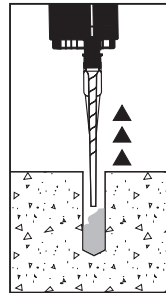

8.) Starting from the back of the cleaned anchor hole, fill the hole to approximately two thirds with adhesive. Slowly withdraw the nozzle as the hole fills to avoid creating air pockets.
For holes with embedment depths greater than 190 mm, an extension must be used.
For horizontal and floor installations in holes deeper than 250 mm, and for overhead installations always, use a piston plug if the hole is 18 mm or larger.

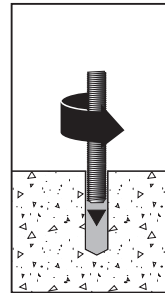

9.) Push the threaded rod or reinforcing bar into the hole while turning slightly to properly distribute the adhesive. The anchor should be clean and free of dirt, grease and oil.
Be sure that the gap is completely filled with mortar. Excess mortar should be visible at the top of the hole.
For overhead application, the threaded rod or reinforcing bar shall be fixed (e.g. wedges) until the mortar has started to harden.

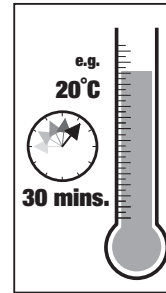

10.) Allow the adhesive to cure for the specified time prior to applying any load. Do not load the anchor until it is fully cured.

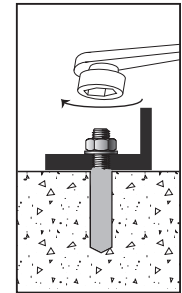

11.) After full curing, the fixture can be installed. Make sure the maximum torque is not exceeded.

Concrete temperature	Gelling working time	Minimum curing time in dry concrete	Minimum curing time in wet concrete
-5°C to -1°C	50 min	5 h	10 h
0°C to +4°C	25 min	3.5 h	7 h
+5°C to +9°C	15 min	2 h	4 h
+10°C to +14°C	10 min	1 h	2 h
+15°C to +19°C	6 min	40 min	80 min
+20°C to +29°C	3 min	30 min	60 min
+30°C to +40°C	2 min	30 min	60 min
Cartridge temperature		+5°C to +40°C	

DESIGN INFORMATION

TENSION LOAD CAPACITIES - THREADED ROD

According to EN 1992-4 (and AS 5216) for a working life of 50 years (temperature range I, II, III and IV) and 100 years (temperature range I and II).

Parameter for calculation of ultimate strength	Notation	Unit	AC200+ - Threaded rod								
			M8	M10	M12	M16	M20	M24	M27	M30	
Steel failure											
Carbon steel											
Characteristic resistance, strength class 4.6 and 4.8	$N_{Rk,S} = N_{Rk,S,C1} = N_{Rk,S,C2}$	[kN]	15	23	34	63	98	141	184	224	
Characteristic resistance, strength class 5.6 and 5.8	$N_{Rk,S} = N_{Rk,S,C1} = N_{Rk,S,C2}$	[kN]	18	29	42	78	122	176	230	280	
Characteristic resistance, strength class 8.8	$N_{Rk,S} = N_{Rk,S,C1} = N_{Rk,S,C2}$	[kN]	29	46	67	125	196	282	368	449	
Stainless steel A2 and A4, and HCR steel											
Characteristic resistance, strength class 50	$N_{Rk,S} = N_{Rk,S,C1} = N_{Rk,S,C2}$	[kN]	18	29	42	79	123	177	230	281	
Characteristic resistance, strength class 70	$N_{Rk,S} = N_{Rk,S,C1} = N_{Rk,S,C2}$	[kN]	26	41	59	110	171	247	-	-	
Characteristic resistance, strength class 80	$N_{Rk,S} = N_{Rk,S,C1} = N_{Rk,S,C2}$	[kN]	29	46	67	126	196	282	-	-	
Partial safety factor¹⁾											
Strength class 4.6 and 5.6	$\gamma_{Ms,N} (= 1/\phi_{Ms,N})$	[-]	2.00								
Strength class 4.8, 5.8 and 8.8	$\gamma_{Ms,N} (= 1/\phi_{Ms,N})$	[-]	1.50								
Strength class 50	$\gamma_{Ms,N} (= 1/\phi_{Ms,N})$	[-]	2.86								
Strength class 70	$\gamma_{Ms,N} (= 1/\phi_{Ms,N})$	[-]	1.87								
Strength class 80	$\gamma_{Ms,N} (= 1/\phi_{Ms,N})$	[-]	1.60								
Combined pullout and concrete failure											
Characteristic resistance in cracked concrete											
Temperature range I: 40°C / 24°C and II: 80°C / 50°C	$T_{Rk,cr} = T_{Rk,C1}$	[N/mm ²]	7.0	7.5	8.0	9.0	8.5	7.0	7.0	7.0	
	$T_{Rk,C2}$	[N/mm ²]	-	-	3.6	3.5	3.3	2.3	-	-	
	$T_{Rk,cr,100}$	[N/mm ²]	5.5	6.0	6.5	6.5	6.5	6.5	6.5	6.5	6.5
Temperature range III: 120°C / 72°C	$T_{Rk,cr} = T_{Rk,C1}$	[N/mm ²]	6.0	6.5	7.0	7.5	7.0	6.0	6.0	6.0	
	$T_{Rk,C2}$	[N/mm ²]	-	-	3.1	3.0	2.8	2.0	-	-	
Temperature range IV: 160°C / 100°C	$T_{Rk,cr} = T_{Rk,C1}$	[N/mm ²]	5.5	5.5	6.0	6.5	6.0	5.5	5.5	5.5	
	$T_{Rk,C2}$	[N/mm ²]	-	-	2.5	2.7	2.5	1.8	-	-	
Characteristic resistance in uncracked concrete											
Temperature range I: 40°C / 24°C and II: 80°C / 50°C	$T_{Rk,uocr} = T_{Rk,uocr,100}$	[N/mm ²]	17.0	17.0	16.0	15.0	14.0	13.0	13.0	13.0	
Temperature range II: 120°C / 72°C	$T_{Rk,uocr}$	[N/mm ²]	15.0	14.0	14.0	13.0	12.0	12.0	11.0	11.0	
Temperature range III: 160°C / 100°C	$T_{Rk,uocr}$	[N/mm ²]	12.0	11.0	11.0	10.0	9.5	9.0	9.0	9.0	
Reduction factor for sustained loads											
Temperature range I: 40°C / 24°C	ψ_{sust}^0	[-]	0.90								
Temperature range II: 80°C / 50°C	ψ_{sust}^0	[-]	0.87								
Temperature range III: 120°C / 72°C	ψ_{sust}^0	[-]	0.75								
Temperature range IV: 160°C / 100°C	ψ_{sust}^0	[-]	0.66								
Increasing factor for concrete strength											
C30/37	Ψ_c	[-]	1.04								
C40/50	Ψ_c	[-]	1.08								
C50/60	Ψ_c	[-]	1.10								
Partial safety factor¹⁾											
Dry and wet concrete, manual air cleaning (MAC)	$\gamma_{Mp} (= 1/\phi_{Mp})$	[-]	1.8 ³⁾								
Dry and wet concrete, compressed air cleaning (CAC)	$\gamma_{Mp} (= 1/\phi_{Mp})$	[-]	1.5 ²⁾								
Dry and wet concrete, hollow drill bit (HDB)	$\gamma_{Mp} (= 1/\phi_{Mp})$	[-]	1.8 ³⁾								
Flooded hole, compressed air cleaning (CAC)	$\gamma_{Mp} (= 1/\phi_{Mp})$	[-]	2.1 ⁴⁾								
Concrete failure											
Data base for concrete cone failure											
Cracked concrete	$k_{Cr,N}$	[-]	7.7								
Uncracked concrete	$k_{Cr,N}$	[-]	11.0								
Characteristic spacing	$s_{Cr,N}$	[mm]	3.0·h _{ef}								
Characteristic edge distance	$c_{Cr,N}$	[mm]	1.5·h _{ef}								
Data base for splitting failure											
Characteristic spacing	$s_{Cr,sp}$	[mm]	2·c _{cr,sp}								
Characteristic edge distance	$c_{Cr,sp}$	[mm]	1.0·h _{ef} ≤ 2·h _{ef} (2.5 · (h/h _{ef})) ≤ 2.4·h _{ef}								
Increasing factor for concrete strength											
C30/37	Ψ_c	[-]	1.21								
C40/50	Ψ_c	[-]	1.41								
C50/60	Ψ_c	[-]	1.55								
Partial safety factor¹⁾											
Dry and wet concrete, manual air cleaning (MAC)	$\gamma_{Mc} (= 1/\phi_{Mc})$	[-]	1.8 ³⁾								
Dry and wet concrete, compressed air cleaning (CAC)	$\gamma_{Mc} (= 1/\phi_{Mc})$	[-]	1.5 ²⁾								
Dry and wet concrete, hollow drill bit (HDB)	$\gamma_{Mc} (= 1/\phi_{Mc})$	[-]	1.8 ³⁾								
Flooded hole, compressed air cleaning (CAC)	$\gamma_{Mc} (= 1/\phi_{Mc})$	[-]	2.1 ⁴⁾								

1) In absence of other national regulations
 2) Partial safety factor $\gamma_{inst}=1.0$ is included
 3) Partial safety factor $\gamma_{inst}=1.2$ is included
 4) Partial safety factor $\gamma_{inst}=1.4$ is included

ADHESIVE ANCHORS

AC200+
CONCRETE ANCHORING SYSTEM

SHEAR LOAD CAPACITIES - THREADED ROD

According to EN 1992-4 (and AS 5216) for a working life of 50 years (temperature range I, II, III and IV) and 100 years (temperature range I and II).

Parameter for calculation of ultimate strength	Notation	Unit	AC208+ - Threaded rod								
			M8	M10	M12	M16	M20	M24	M27	M30	
Steel failure											
Data base for steel failure without level arm											
Carbon steel											
Characteristic resistance, strength class 4.6 and 4.8	$V_{Rk,s}^0$	[kN]	9	14	20	38	59	85	110	135	
	$V_{Rk,s,C1}^0$	[kN]	6.3	9.8	14.0	26.6	41.3	59.5	77.0	94.5	
	$V_{Rk,s,C2}^0$	[kN]	-	-	14.0	26.6	41.3	59.5	-	-	
Characteristic resistance, strength class 5.6 and 5.8	$V_{Rk,s}^0$	[kN]	11	17	25	47	74	106	138	168	
	$V_{Rk,s,C1}^0$	[kN]	7.7	11.9	17.5	32.9	51.8	74.2	96.6	117.6	
	$V_{Rk,s,C2}^0$	[kN]	-	-	17.5	32.9	51.8	74.2	-	-	
Characteristic resistance, strength class 8.8	$V_{Rk,s}^0$	[kN]	15	23	34	63	98	141	184	224	
	$V_{Rk,s,C1}^0$	[kN]	10.5	16.1	23.8	44.1	68.6	98.7	128.8	156.8	
	$V_{Rk,s,C2}^0$	[kN]	-	-	23.8	44.1	68.6	98.7	-	-	
Stainless steel A2 and A4, and HCR steel											
Characteristic resistance, strength class 50	$V_{Rk,s}^0$	[kN]	9	15	21	39	61	88	115	140	
	$V_{Rk,s,C1}^0$	[kN]	6.3	10.5	14.7	27.3	42.7	61.6	80.5	98.0	
	$V_{Rk,s,C2}^0$	[kN]	-	-	14.7	27.3	42.7	61.6	-	-	
Characteristic resistance, strength class 70	$V_{Rk,s}^0$	[kN]	13	20	30	55	86	124	-	-	
	$V_{Rk,s,C1}^0$	[kN]	9.1	14.0	21.0	38.5	60.2	86.8	-	-	
	$V_{Rk,s,C2}^0$	[kN]	-	-	21.0	38.5	60.2	86.8	-	-	
Characteristic resistance, strength class 80	$V_{Rk,s}^0$	[kN]	15	23	34	63	98	141	-	-	
	$V_{Rk,s,C1}^0$	[kN]	10.5	16.1	23.8	44.1	68.6	98.7	-	-	
	$V_{Rk,s,C2}^0$	[kN]	-	-	23.8	44.1	68.6	98.7	-	-	
Ductility factor	k_7	[-]	1.0								
Data base for steel failure with level arm											
Carbon steel											
Characteristic resistance, strength class 4.6 and 4.8	$M_{Rk,s}^0$	[Nm]	15	30	52	133	260	449	666	900	
Characteristic resistance, strength class 5.6 and 5.8	$M_{Rk,s}^0$	[Nm]	19	37	65	166	324	560	833	1123	
Characteristic resistance, strength class 8.8	$M_{Rk,s}^0$	[Nm]	30	60	105	266	519	896	1333	1797	
Stainless steel A2 and A4, and HCR steel											
Characteristic resistance, strength class 50	$M_{Rk,s}^0$	[Nm]	19	37	66	167	325	561	832	1125	
Characteristic resistance, strength class 70	$M_{Rk,s}^0$	[Nm]	26	52	92	232	454	784	-	-	
Characteristic resistance, strength class 80	$M_{Rk,s}^0$	[Nm]	30	59	105	266	519	896	-	-	
Partial safety factor¹⁾											
Strength class 4.6 and 5.6	$\gamma_{Ms,V} (= 1/\phi_{Ms,V})$	[-]	1.67								
Strength class 4.8, 5.8 and 8.8	$\gamma_{Ms,V} (= 1/\phi_{Ms,V})$	[-]	1.25								
Strength class 50	$\gamma_{Ms,V} (= 1/\phi_{Ms,V})$	[-]	2.38								
Strength class 70	$\gamma_{Ms,V} (= 1/\phi_{Ms,V})$	[-]	1.56								
Strength class 80	$\gamma_{Ms,V} (= 1/\phi_{Ms,V})$	[-]	1.33								
Concrete failure											
Data base for pry-out failure											
Pryout factor	k_8	[-]	2.0								
Partial safety factor ¹⁾	$\gamma_{Mc} (= 1/\phi_{Mc})$	[-]	1.5 ²⁾								
Data base for edge failure											
Effective length of anchor	ℓ_f	[-]	$\min(h_{ef}; 12 d_{nom})$							$\min(h_{ef}; 300\text{mm})$	
Partial safety factor	$\gamma_{Mc} (= 1/\phi_{Mc})$	[-]	1.5 ²⁾								

1) In absence of other national regulations

 2) Partial safety factor $\gamma_2=1.0$ is included.

TENSION LOAD CAPACITIES - REINFORCING BAR

According to EN 1992-4 (and AS 5216) for a working life of 50 years (temperature range I, II, III and IV) and 100 years (temperature range I and II).

Parameter for calculation of ultimate strength	Notation	Unit	AC208+ - Reinforcing bar										
			Ø8	Ø10	Ø12	Ø14	Ø16	Ø20	Ø24	Ø25	Ø28	Ø32	
Steel failure													
Characteristic resistance	$N_{Rk,S} = N_{Rk,S,C1}$	[kN]	$A_s \cdot f_{yk}$										
Cross section area	A_s	[kN]	50	79	113	154	201	314	452	491	616	804	
Cross section area	f_{yk}	[kN]	To be taken from specification of reinforcing bar										
Partial safety factor ¹⁾	$\gamma_{Ms,N} (= 1/\phi_{Ms,N})$	[-]	1.40										
Combined pullout and concrete failure													
Characteristic resistance in cracked concrete													
Temperature Range I: 40°C / 24°C and II: 80°C / 50°C	$\tau_{Rk,cr} = \tau_{Rk,C1}$	[N/mm ²]	5.5	5.5	6.0	6.5	6.5	6.5	6.5	7.0	7.0	7.0	
	$\tau_{Rk,cr,100}$	[N/mm ²]	4.5	4.5	4.5	4.5	4.5	4.0	4.0	4.0	4.0	4.0	
Temperature Range III: 120°C / 72°C	$\tau_{Rk,cr} = \tau_{Rk,C1}$	[N/mm ²]	4.5	5.0	5.0	5.5	5.5	5.5	5.5	6.0	6.0	6.0	
Temperature Range IV: 160°C / 100°C	$\tau_{Rk,cr} = \tau_{Rk,C1}$	[N/mm ²]	4.0	4.5	4.5	5.0	5.0	5.0	5.0	5.0	5.0	5.0	
Characteristic resistance in uncracked concrete													
Temperature Range I: 40°C / 24°C and II: 80°C / 50°C	$\tau_{Rk,ucr} = \tau_{Rk,ucr,100}$	[N/mm ²]	14.0	14.0	14.0	14.0	13.0	13.0	13.0	13.0	13.0	13.0	
Temperature Range III: 120°C / 72°C	$\tau_{Rk,ucr}$	[N/mm ²]	13.0	12.0	12.0	12.0	12.0	11.0	11.0	11.0	11.0	11.0	
Temperature Range IV: 160°C / 100°C	$\tau_{Rk,ucr}$	[N/mm ²]	9.5	9.5	9.5	9.0	9.0	9.0	9.0	9.0	8.5	8.5	
Increasing factor for sustained load													
Temperature range I: 40°C / 24°C	ψ_{sus}^0	[-]	0.90										
Temperature range II: 80°C / 50°C	ψ_{sus}^0	[-]	0.87										
Temperature range III: 120°C / 72°C	ψ_{sus}^0	[-]	0.75										
Temperature range IV: 160°C / 100°C	ψ_{sus}^0	[-]	0.66										
Increasing factor for concrete strength													
C30/37	ψ_c	[-]	1.04										
C40/50	ψ_c	[-]	1.08										
C50/60	ψ_c	[-]	1.10										
Partial safety factor¹⁾													
Dry and wet concrete, manual air cleaning (MAC)	$\gamma_{Mp} (= 1/\phi_{Mp})$	[-]	1.8 ³⁾										
Dry and wet concrete, compressed air cleaning (CAC)	$\gamma_{Mp} (= 1/\phi_{Mp})$	[-]					1.5 ²⁾						
Dry and wet concrete, hollow drill bit (HDB)	$\gamma_{Mp} (= 1/\phi_{Mp})$	[-]					1.8 ³⁾						
Flooded hole, compressed air cleaning (CAC)	$\gamma_{Mp} (= 1/\phi_{Mp})$	[-]					2.1 ⁴⁾						
Concrete failure													
Data base for concrete cone failure													
Cracked concrete	$k_{cr,N}$	[-]	7.7										
Uncracked concrete	$k_{cr,N}$	[-]	11.0										
Characteristic spacing	$s_{cr,N}$	[mm]	$3.0 \cdot h_{ef}$										
Characteristic edge distance	$c_{cr,N}$	[mm]	$1.5 \cdot h_{ef}$										
Data base for splitting failure													
Characteristic spacing	$s_{cr,sp}$	[mm]	$2 \cdot c_{cr,sp}$										
Characteristic edge distance	$c_{cr,sp}$	[mm]	$1.0 \cdot h_{ef} \leq 2 \cdot h_{ef} (2.5 - (h/h_{ef})) \leq 2.4 \cdot h_{ef}$										
Increasing factor for concrete strength													
C30/37	ψ_c	[-]	1.21										
C40/50	ψ_c	[-]	1.41										
C50/60	ψ_c	[-]	1.55										
Partial safety factor¹⁾													
Dry and wet concrete, manual air cleaning (MAC)	$\gamma_{Mc} (= 1/\phi_{Mc})$	[-]	1.8 ³⁾										
Dry and wet concrete, compressed air cleaning (CAC)	$\gamma_{Mc} (= 1/\phi_{Mc})$	[-]					1.5 ²⁾						
Dry and wet concrete, hollow drill bit (HDB)	$\gamma_{Mc} (= 1/\phi_{Mc})$	[-]					1.8 ³⁾						
Flooded hole, compressed air cleaning (CAC)	$\gamma_{Mc} (= 1/\phi_{Mc})$	[-]					2.1 ⁴⁾						

1) In absence of other national regulations
 2) Partial safety factor $\gamma_{inst}=1.0$ is included
 3) Partial safety factor $\gamma_{inst}=1.2$ is included

4) Partial safety factor $\gamma_{inst}=1.4$ is included

SHEAR LOAD CAPACITIES - REINFORCING BAR

According to EN 1992-4 (and AS 5216) for a working life of 50 years (temperature range I, II, III and IV) and 100 years (temperature range I and II).

Parameter for calculation of ultimate strength	Notation	Unit	AC200+ - Reinforcing bar											
			Ø8	Ø10	Ø12	Ø14	Ø16	Ø20	Ø24	Ø25	Ø28	Ø32		
Steel failure														
Data base for steel failure without level arm														
Characteristic resistance	$V_{Rk,S}^0$	[kN]	$0.5 \cdot A_s \cdot f_{uk}$											
	$V_{Rk,S,C1}^0$	[kN]	$0.35 \cdot A_s \cdot f_{uk}$											
Cross section area	A_s	[kN]	50	79	113	154	201	314	452	491	616	804		
Cross section area	f_{uk}	[kN]	To be taken from specification of reinforcing bar											
Partial safety factor ¹⁾	$\gamma_{Ms,V} (= 1/\phi_{Ms,V})$	[-]	1.50											
Ductility factor	k_7	[-]	1.0											
Data base for steel failure with level arm														
Characteristic resistance	$M_{Rk,S}^0$	[kN]	$1.2 \cdot W_{el} \cdot f_{uk}$											
Cross section area	W_{el}	[kN]	50	98	170	269	402	785	1357	1534	2155	3217		
Cross section area	f_{uk}	[kN]	To be taken from specification of reinforcing bar											
Partial safety factor ¹⁾	$\gamma_{Ms,V} (= 1/\phi_{Ms,V})$	[-]	1.50											
Concrete failure														
Data base for pry-out failure														
Pryout factor	k_b	[-]	2.0											
Partial safety factor ¹⁾	$\gamma_{Mc} (= 1/\phi_{Mc})$	[-]	1.5 ²⁾											
Data base for edge failure														
Effective length of anchor	ℓ_f	[-]	$\min(h_{ef}; 12 d_{nom})$								$\min(h_{ef}; 300\text{mm})$			
Partial safety factor ¹⁾	$\gamma_{Mc} (= 1/\phi_{Mc})$	[-]	1.5 ²⁾											

1) In absence of other national regulations

2) Partial safety factor $\gamma_2=1.0$ is included.

PRECALCULATED TENSION AND SHEAR CAPACITIES - THREADED ROD

According to EN 1992-4 (and AS 5216).

- The following tables are meant to give the designer aid in the preliminary design process. No responsibility is taken for the correctness of these data.
- The given values are valid for normal concrete C20/25 ($f_c = 20$ MPa) and static/quasi-static loads with the exact dimensional information given. For any other conditions, the use of DDA is recommended.
- The values in the table below are strength design level loads. This assumes a safety factor is included both on the loading and the resistance.
- For cracked concrete, splitting failure is not considered assuming that a reinforcement is present which limits the cracks to 0.3 mm.
- Precalculated design resistance capacities are given for threaded rods only, values for reinforcing bars can be found in the relevant approval documents.
- For further details and background information, please see the introduction of this manual.

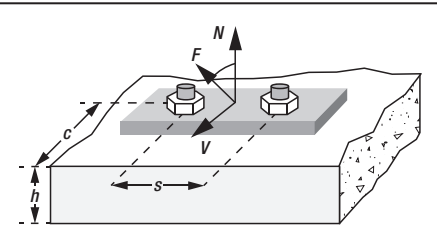

Influence of steel grades									
Size	Property	Carbon steel					Stainless steel / HCR steel		
		4.6	4.8	5.6	5.8	8.8	Class 50	Class 70	Class 80
M8	N_{Rd} [kN]	7.5	10.0	9.0	12.0	19.3	6.3	13.9	18.1
	V_{Rd} [kN]	5.4	7.2	6.6	8.8	12.0	3.8	8.3	11.3
M10	N_{Rd} [kN]	11.5	15.3	14.5	19.3	30.7	10.1	21.9	28.8
	V_{Rd} [kN]	8.4	11.2	10.2	13.6	18.4	6.3	12.8	17.3
M12	N_{Rd} [kN]	17.0	22.7	15.0	28.0	44.7	14.7	31.6	41.9
	V_{Rd} [kN]	12.0	16.0	15.0	20.0	27.2	8.8	19.2	25.6
M16	N_{Rd} [kN]	31.5	42.0	39.0	52.0	83.3	27.6	58.8	78.8
	V_{Rd} [kN]	22.8	30.4	28.1	37.6	50.4	16.4	35.3	47.4
M20	N_{Rd} [kN]	49.0	65.3	61.0	81.3	130.7	43.0	91.4	122.5
	V_{Rd} [kN]	35.3	47.2	44.3	59.2	78.4	25.6	55.1	73.7
M24	N_{Rd} [kN]	70.5	94.0	88.0	117.3	188.0	61.9	132.1	176.3
	V_{Rd} [kN]	50.9	68.0	63.5	84.8	112.8	37.0	79.5	106.0
M27	N_{Rd} [kN]	92.0	122.7	115.0	153.3	245.3	80.4	-	-
	V_{Rd} [kN]	65.9	88.0	82.6	110.4	147.2	48.3	-	-
M30	N_{Rd} [kN]	112.0	149.3	140.0	186.7	299.3	98.3	-	-
	V_{Rd} [kN]	80.8	108.0	100.6	134.4	179.2	58.8	-	-

Instructions:

- The steel grade potentially influences the load capacity of the anchor. Table depicts ultimate steel strengths of threaded rods for given steel grades.
- The steel strength equals the load capacity of the anchor provided other failure modes, i.e. concrete failure or pullout failure, do not yield lower strengths and therefore do not control the anchor capacity.
- To determine the critical failure mode, the steel strength identified in the table has to be compared with the concrete and pullout strengths in the following tables.

M8	C20/25 (f_c = 20 MPa) 8.8 steel dry/wet concrete CAC, 50 years	Anchoring located far from any edge					Anchoring located close to an edge				
Embedment depth	h _{ef} [mm]	80									
Member thickness	h [mm]	110									
Edge distance	c [mm]	-	-	-	-	-	35	35	35	35	35
Anchor spacing	s [mm]	0	40	240	40	240	0	40	240	40	240
	N _{Rd} [kN]	9.4	12.4	18.8	16.7	37.5	4.8	6.3	9.5	9.2	19.1
	F _{Rd} ^{45°} [kN]	8.8	13.7	17.7	18.9	35.3	2.4	3.2	4.8	3.6	5.6
	V _{Rd} [kN]	11.7	23.4	23.4	33.5	46.7	2.0	2.8	4.0	2.8	4.0
	N _{Rd} [kN]	8.0	10.9	16.1	15.2	32.2	4.2	5.6	8.3	8.5	16.7
	F _{Rd} ^{45°} [kN]	8.1	12.3	16.2	17.2	32.3	2.3	3.1	4.6	3.5	5.5
	V _{Rd} [kN]	11.7	21.8	23.4	30.3	46.7	2.0	2.8	4.0	2.8	4.0
	N _{Rd} [kN]	19.3	26.6	38.7	31.0	77.3	10.6	11.8	17.7	14.0	37.5
	F _{Rd} ^{45°} [kN]	12.4	21.1	24.7	31.6	49.4	3.8	5.0	7.2	5.2	8.0
	V _{Rd} [kN]	11.7	23.4	23.4	46.7	46.7	2.8	3.9	5.6	3.9	5.6
	N _{Rd} [kN]	19.3	24.2	38.7	29.3	77.3	10.4	11.8	17.7	14.0	37.5
	F _{Rd} ^{45°} [kN]	12.4	20.2	24.7	30.6	49.4	3.8	5.0	7.2	5.2	8.0
	V _{Rd} [kN]	11.7	23.4	23.4	46.7	46.7	2.8	3.9	5.6	3.9	5.6

■ - Steel strengths controls ■ - Concrete strength controls ■ - Anchor pullout strength controls

M10	C20/25 (f_c = 20 MPa) 8.8 steel dry/wet concrete CAC, 50 years	Anchoring located far from any edge					Anchoring located close to an edge				
Embedment depth	h _{ef} [mm]	100									
Member thickness	h [mm]	130									
Edge distance	c [mm]	-	-	-	-	-	40	40	40	40	40
Anchor spacing	s [mm]	0	50	300	50	300	0	50	300	50	300
	N _{Rd} [kN]	15.7	20.0	31.4	26.2	62.8	7.8	9.9	15.5	14.0	31.0
	F _{Rd} ^{45°} [kN]	14.4	22.1	28.9	29.6	57.8	3.3	4.6	6.6	5.0	7.4
	V _{Rd} [kN]	18.6	37.1	37.1	52.3	74.2	2.6	3.7	5.2	3.7	5.2
	N _{Rd} [kN]	13.6	18.0	27.2	24.5	54.5	6.9	9.2	13.9	13.5	27.7
	F _{Rd} ^{45°} [kN]	13.3	20.4	26.7	27.7	53.3	3.2	4.5	6.4	4.9	7.4
	V _{Rd} [kN]	18.6	36.0	37.1	49.0	74.2	2.6	3.7	5.2	3.7	5.2
	N _{Rd} [kN]	30.7	38.3	61.3	44.6	122.7	14.3	15.8	23.3	18.7	48.3
	F _{Rd} ^{45°} [kN]	19.6	32.0	39.2	47.3	78.5	5.0	6.7	9.5	6.9	10.4
	V _{Rd} [kN]	18.6	37.1	37.1	74.2	74.2	3.7	5.2	7.4	5.2	7.4
	N _{Rd} [kN]	29.3	35.0	58.6	41.8	117.3	14.3	15.8	23.3	18.7	48.3
	F _{Rd} ^{45°} [kN]	19.3	30.6	38.6	45.4	77.2	5.0	6.7	9.5	6.9	10.4
	V _{Rd} [kN]	18.6	37.1	37.1	74.2	74.2	3.7	5.2	7.4	5.2	7.4

■ - Steel strengths controls ■ - Concrete strength controls ■ - Anchor pullout strength controls



The DEWALT Design Assist is a powerful anchor design software which helps you to design simple and complex anchorages. The design data of all DEWALT anchor products is readily available. To download this software for free, go to anchors.DeWALT.com/anchors/tech-support-software/DeWALT_design_assist.php

M12	C20/25 (f_c = 20 MPa) 8.8 steel dry/wet concrete CAC, 50 years	Anchoring located far from any edge					Anchoring located close to an edge				
Embedment depth	h_{ef} [mm]	120									
Member thickness	h [mm]	150									
Edge distance	c [mm]	-	-	-	-	-	45	45	45	45	45
Anchor spacing	s [mm]	0	60	360	60	360	0	60	360	60	360
40/24 80/50 	N_{Rd} [kN]	24.1	29.7	48.3	37.2	96.5	11.8	14.5	23.6	19.8	47.1
	$F_{Rd}^{45^\circ}$ [kN]	21.6	32.5	43.2	42.1	86.4	4.4	6.1	8.8	6.5	9.4
	V_{Rd} [kN]	27.0	53.9	53.9	74.5	107.8	3.3	4.8	6.6	4.8	6.6
120/72 	N_{Rd} [kN]	21.1	27.1	42.2	35.6	84.4	10.5	13.5	21.0	19.3	42.1
	$F_{Rd}^{45^\circ}$ [kN]	20.1	30.6	40.2	40.2	80.4	4.3	6.0	8.6	6.5	9.4
	V_{Rd} [kN]	27.0	53.9	53.9	71.1	107.8	3.3	4.8	6.6	4.8	6.6
40/24 80/50 	N_{Rd} [kN]	43.1	50.3	86.2	58.7	172.4	18.6	20.6	30.2	24.3	63.0
	$F_{Rd}^{45^\circ}$ [kN]	28.1	44.2	56.3	64.5	112.6	6.3	8.6	12.1	9.0	13.2
	V_{Rd} [kN]	27.0	53.9	53.9	107.8	107.8	4.7	6.8	9.4	6.8	9.4
120/72 	N_{Rd} [kN]	42.2	49.9	84.4	58.7	168.9	18.6	20.6	30.2	24.3	63.0
	$F_{Rd}^{45^\circ}$ [kN]	27.9	44.0	55.8	64.5	111.7	6.3	8.6	12.1	9.0	13.2
	V_{Rd} [kN]	27.0	53.9	53.9	107.8	107.8	4.7	6.8	9.4	6.8	9.4

■ - Steel strengths controls ■ - Concrete strength controls ■ - Anchor pullout strength controls

M16	C20/25 (f_c = 20 MPa) 8.8 steel dry/wet concrete CAC, 50 years	Anchoring located far from any edge					Anchoring located close to an edge				
Embedment depth	h_{ef} [mm]	160									
Member thickness	h [mm]	196									
Edge distance	c [mm]	-	-	-	-	-	50	50	50	50	50
Anchor spacing	s [mm]	0	75	480	75	480	0	75	480	75	480
40/24 72/43 	N_{Rd} [kN]	46.5	53.7	92.9	62.1	185.8	21.4	24.7	42.8	31.1	90.3
	$F_{Rd}^{45^\circ}$ [kN]	41.0	59.4	81.9	70.3	163.9	6.2	8.9	12.4	9.3	12.5
	V_{Rd} [kN]	50.2	100.5	100.5	124.2	201.0	4.4	6.6	8.8	6.6	8.8
40/24 72/43 	N_{Rd} [kN]	40.2	48.7	80.4	59.5	160.8	19.2	23.2	38.4	31.0	76.7
	$F_{Rd}^{45^\circ}$ [kN]	37.9	55.1	75.8	67.3	151.6	6.1	8.7	12.2	9.2	12.5
	V_{Rd} [kN]	50.2	97.3	100.5	119.0	201.0	4.4	6.6	8.8	6.6	8.8
40/24 72/43 	N_{Rd} [kN]	66.4	76.7	132.7	88.7	265.5	27.7	30.4	45.0	35.7	94.9
	$F_{Rd}^{45^\circ}$ [kN]	48.5	73.8	97.1	100.4	194.1	8.6	12.1	16.5	12.6	17.6
	V_{Rd} [kN]	50.2	100.5	100.5	177.5	201.0	6.2	9.3	12.4	9.3	12.4
40/24 72/43 	N_{Rd} [kN]	66.4	76.7	132.7	88.7	265.5	27.7	30.4	45.0	35.7	94.9
	$F_{Rd}^{45^\circ}$ [kN]	48.5	73.8	97.1	100.4	194.1	8.6	12.1	16.5	12.6	17.6
	V_{Rd} [kN]	50.2	100.5	100.5	177.5	201.0	6.2	9.3	12.4	9.3	12.4

■ - Steel strengths controls ■ - Concrete strength controls ■ - Anchor pullout strength controls



The DEWALT Design Assist is a powerful anchor design software which helps you to design simple and complex anchorages. The design data of all DEWALT anchor products is readily available. To download this software for free, go to anchors.DeWALT.com/anchors/tech-support-software/DeWALT_design_assist.php

M20	C20/25 (f_c = 20 MPa) 8.8 steel dry/wet concrete CAC, 50 years	Anchoring located far from any edge					Anchoring located close to an edge				
Embedment depth	h_{ef} [mm]	200									
Member thickness	h [mm]	248									
Edge distance	c [mm]	-	-	-	-	-	60	60	60	60	60
Anchor spacing	s [mm]	0	95	600	95	600	0	95	600	95	600
40/24 80/50 	N_{Rd} [kN]	64.9	75.2	129.9	87.1	259.7	29.6	34.3	59.2	43.3	133.0
	$F_{Rd}^{45^\circ}$ [kN]	60.3	85.1	120.5	98.6	241.1	8.7	12.6	17.5	13.2	17.6
	V_{Rd} [kN]	78.4	150.4	156.8	174.2	313.6	6.2	9.5	12.5	9.5	12.5
120/72 	N_{Rd} [kN]	58.6	70.6	117.3	85.3	234.6	28.0	33.7	55.9	43.3	111.9
	$F_{Rd}^{45^\circ}$ [kN]	56.9	79.8	113.9	96.6	227.7	8.6	12.6	17.3	13.2	17.6
	V_{Rd} [kN]	78.4	141.1	156.8	170.7	313.6	6.2	9.5	12.5	9.5	12.5
40/24 80/50 	N_{Rd} [kN]	77.3	89.5	154.6	103.7	309.2	32.1	35.2	52.1	41.4	110.0
	$F_{Rd}^{45^\circ}$ [kN]	66.1	96.7	132.1	124.2	264.2	11.7	16.5	22.3	17.2	24.9
	V_{Rd} [kN]	78.4	156.8	156.8	248.9	313.6	8.8	13.4	17.6	13.4	17.6
120/72 	N_{Rd} [kN]	77.3	89.5	154.6	103.7	309.2	32.1	35.2	52.1	41.4	110.0
	$F_{Rd}^{45^\circ}$ [kN]	66.1	96.7	132.1	117.3	264.2	11.7	16.5	22.3	17.2	24.9
	V_{Rd} [kN]	78.4	156.8	156.8	207.4	313.6	8.8	13.4	17.6	13.4	17.6

■ - Steel strengths controls ■ - Concrete strength controls ■ - Anchor pullout strength controls

M24	C20/25 (f_c = 20 MPa) 8.8 steel dry/wet concrete CAC, 50 years	Anchoring located far from any edge					Anchoring located close to an edge				
Embedment depth	h_{ef} [mm]	240									
Member thickness	h [mm]	296									
Edge distance	c [mm]	-	-	-	-	-	120	120	120	120	120
Anchor spacing	s [mm]	0	115	720	115	720	0	115	720	115	720
40/24 80/50 	N_{Rd} [kN]	84.4	99.0	168.9	114.8	337.8	45.5	52.8	91.0	65.4	189.7
	$F_{Rd}^{45^\circ}$ [kN]	82.0	112.0	163.9	129.9	327.8	19.7	25.1	39.3	26.5	43.9
	V_{Rd} [kN]	112.8	198.0	225.6	229.6	451.2	15.5	20.5	31.1	20.5	31.1
120/72 	N_{Rd} [kN]	72.4	89.5	144.8	112.0	289.5	42.1	52.1	84.3	65.4	168.5
	$F_{Rd}^{45^\circ}$ [kN]	74.8	101.3	149.6	126.7	299.3	19.3	25.0	38.5	26.5	43.9
	V_{Rd} [kN]	112.8	179.0	225.6	224.0	451.2	15.5	20.5	31.1	20.5	31.1
40/24 80/50 	N_{Rd} [kN]	121.9	141.4	243.9	164.0	487.7	56.2	61.8	91.3	72.0	185.7
	$F_{Rd}^{45^\circ}$ [kN]	99.4	147.5	198.9	185.5	397.8	26.8	33.4	50.3	35.0	60.2
	V_{Rd} [kN]	112.8	225.6	225.6	328.0	451.2	21.9	28.9	43.9	28.9	43.9
120/72 	N_{Rd} [kN]	121.9	141.4	243.9	164.0	487.7	56.2	61.8	91.3	72.0	185.7
	$F_{Rd}^{45^\circ}$ [kN]	99.4	147.5	198.9	185.5	397.8	26.8	33.4	50.3	35.0	60.2
	V_{Rd} [kN]	112.8	225.6	225.6	328.0	451.2	21.9	28.9	43.9	28.9	43.9

■ - Steel strengths controls ■ - Concrete strength controls ■ - Anchor pullout strength controls



The DEWALT Design Assist is a powerful anchor design software which helps you to design simple and complex anchorages. The design data of all DEWALT anchor products is readily available. To download this software for free, go to anchors.DeWALT.com/anchors/tech-support-software/DeWALT_design_assist.php

M27	C20/25 ($f_c = 20$ MPa) 8.8 steel dry/wet concrete CAC, 50 years	Anchoring located far from any edge					Anchoring located close to an edge				
		Embedment depth	h_{ef} [mm]								
Member thickness	h [mm]	334									
Edge distance	c [mm]	-	-	-	-	-	125	125	125	125	125
Anchor spacing	s [mm]	0	75	810	75	810	0	75	810	75	810
40/24 80/50 	N_{Rd} [kN]	101.8	111.3	203.7	121.6	407.4	52.8	57.7	105.6	65.9	232.7
	$F_{Rd}^{45^\circ}$ [kN]	102.2	125.9	204.3	137.6	408.6	22.2	26.0	44.3	26.9	49.1
	V_{Rd} [kN]	147.2	222.6	294.4	243.2	588.8	17.4	20.8	34.7	20.8	34.7
120/72 	N_{Rd} [kN]	91.6	103.8	183.2	118.5	366.4	51.6	57.7	103.2	65.9	206.3
	$F_{Rd}^{45^\circ}$ [kN]	95.8	117.5	191.7	134.0	383.3	22.0	26.0	44.1	26.9	49.1
	V_{Rd} [kN]	147.2	207.7	294.4	236.9	588.8	17.4	20.8	34.7	20.8	34.7
40/24 80/50 	N_{Rd} [kN]	145.5	159.0	291.0	173.7	582.0	65.8	69.6	106.9	76.3	218.9
	$F_{Rd}^{45^\circ}$ [kN]	124.2	175.2	248.4	196.5	496.7	30.3	35.1	57.0	36.0	68.0
	V_{Rd} [kN]	147.2	294.4	294.4	347.4	588.8	24.5	29.4	49.0	29.4	49.0
120/72 	N_{Rd} [kN]	145.5	159.0	291.0	173.7	582.0	65.8	69.6	106.9	76.3	218.9
	$F_{Rd}^{45^\circ}$ [kN]	124.2	175.2	248.4	196.5	496.7	30.3	35.1	57.0	36.0	68.0
	V_{Rd} [kN]	147.2	294.4	294.4	347.4	588.8	24.5	29.4	49.0	29.4	49.0

■ - Steel strengths controls ■ - Concrete strength controls ■ - Anchor pullout strength controls

M30	C20/25 ($f_c = 20$ MPa) 8.8 steel dry/wet concrete CAC, 50 years	Anchoring located far from any edge					Anchoring located close to an edge				
		Embedment depth	h_{ef} [mm]								
Member thickness	h [mm]	370									
Edge distance	c [mm]	-	-	-	-	-	80	80	80	80	80
Anchor spacing	s [mm]	0	140	900	140	900	0	140	900	140	900
40/24 80/50 	N_{Rd} [kN]	119.3	137.8	238.6	159.3	477.2	52.9	61.2	105.8	77.3	241.4
	$F_{Rd}^{45^\circ}$ [kN]	121.5	156.0	243.1	180.2	486.1	15.7	23.3	31.4	24.5	31.7
	V_{Rd} [kN]	179.2	275.7	358.4	318.6	716.8	11.2	17.7	22.4	17.7	22.4
120/72 	N_{Rd} [kN]	113.1	134.9	226.2	159.3	452.4	52.9	61.2	105.7	77.3	211.4
	$F_{Rd}^{45^\circ}$ [kN]	117.7	152.6	235.3	180.2	470.7	15.7	23.3	31.4	24.5	31.7
	V_{Rd} [kN]	179.2	269.8	358.4	318.6	716.8	11.2	17.7	22.4	17.7	22.4
40/24 80/50 	N_{Rd} [kN]	170.4	196.9	340.8	227.6	681.6	69.4	76.2	112.8	89.5	239.7
	$F_{Rd}^{45^\circ}$ [kN]	148.2	215.7	296.5	257.4	592.9	21.9	32.0	41.9	33.2	44.7
	V_{Rd} [kN]	179.2	358.4	358.4	455.1	716.8	15.8	25.0	31.6	25.0	31.6
120/72 	N_{Rd} [kN]	170.4	196.9	340.8	227.6	681.6	69.4	76.2	112.8	89.5	239.7
	$F_{Rd}^{45^\circ}$ [kN]	148.2	215.7	296.5	257.4	592.9	21.9	32.0	41.9	33.2	44.7
	V_{Rd} [kN]	179.2	358.4	358.4	455.1	716.8	15.8	25.0	31.6	25.0	31.6

■ - Steel strengths controls ■ - Concrete strength controls ■ - Anchor pullout strength controls



The DEWALT Design Assist is a powerful anchor design software which helps you to design simple and complex anchorages. The design data of all DEWALT anchor products is readily available. To download this software for free, go to anchors.DeWALT.com/anchors/tech-support-software/DeWALT_design_assist.php

MATERIAL INFORMATION

MATERIAL SPECIFICATIONS - THREADED ROD

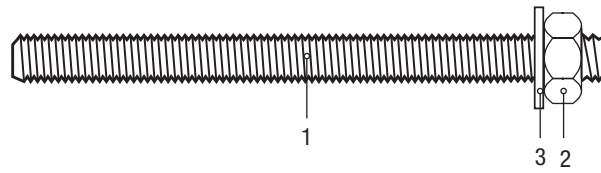

Part no.	Designation	Material
Carbon steel 4.6, 4.8, 5.6, 5.8, 8.8		
Material acc. to EN ISO 683-4:2018 or EN 10263:2017 Electro plated $\geq 5 \mu\text{m}$ acc. to EN ISO 4042:2018 Hot-dip galvanised $\geq 40 \mu\text{m}$ acc. to EN ISO 1461:2009 or EN ISO 10684:2004 Sheradised $\geq 45 \mu\text{m}$ acc. to EN ISO 17688:2016		
1	Anchor rod	Strength class 4.6, $f_{uk} = 400 \text{ MPa}$; $f_{yk} = 240 \text{ MPa}$ Strength class 4.8, $f_{uk} = 400 \text{ MPa}$; $f_{yk} = 320 \text{ MPa}$ Strength class 5.6, $f_{uk} = 500 \text{ MPa}$; $f_{yk} = 300 \text{ MPa}$ Strength class 5.8, $f_{uk} = 500 \text{ MPa}$; $f_{yk} = 400 \text{ MPa}$ Strength class 8.8, $f_{uk} = 800 \text{ MPa}$; $f_{yk} = 640 \text{ MPa}$
2	Hexagon nut	Strength class 4 for threaded rod class 4.6 & 4.8 Strength class 5 for threaded rod class 5.6 & 5.8 Strength class 8 for threaded rod class 8.8
3	Washer	EN ISO 887:2006; EN ISO 7089:2000; EN ISO 7093:2000; EN ISO 7094:2000
Stainless steel A2, A4, and HCR		
Material acc. to EN ISO 3506-1:2020 Stainless steel A2: 1.4301 / 1.4307 / 1.4311 / 1.4567 / 1.4541 Stainless steel A4: 1.4401 / 1.4404 / 1.4571 / 1.4362 / 1.4578 High corrosion resistance steel: 1.4529 / 1.4565		
1	Anchor rod	Strength class 50, $f_{uk} = 500 \text{ MPa}$; $f_{yk} = 210 \text{ MPa}$ Strength class 70(1), $f_{uk} = 700 \text{ MPa}$; $f_{yk} = 450 \text{ MPa}$ Strength class 80(1)2), $f_{uk} = 800 \text{ MPa}$; $f_{yk} = 600 \text{ MPa}$
2	Hexagon nut	Strength class 50 for threaded rod class 50 Strength class 70 for threaded rod class 70 Strength class 80 for threaded rod class 80
3	Washer	EN ISO 887:2006; EN ISO 7089:2000; EN ISO 7093:2000; EN ISO 7094:2000

- 1) Property class 70 or 80 for threaded rods and hexagon nuts up to M24
- 2) Property class 80 only for stainless steel A4 and high corrosion resistance steel HCR

MATERIAL SPECIFICATIONS - REINFORCING BAR



Extract of EN 1992-1-1 Annex C, Table C.1	Class B	Class C
Characteristic yield strength f_{yk} or $f_{0.2k}$ [MPa]	400 to 600	
Minimum value of $k = (f_t / f_y)_k$ [-]	≥ 1.08	$\geq 1.15 < 1.35$
Characteristic strain at maximum force ϵ_{uk} [%]	≥ 5.0	≥ 7.5
Bendability	Bend/Rebend test	
Maximum deviation from nominal mass [%]	± 6.0 for nominal bar size $\leq 8 \text{ mm}$; ± 4.5 for nominal bar size $> 12 \text{ mm}$	
Extract of EN 1992-1-1 Annex C, Table C.2N	Class B	Class C
Minimum value of related rib area $f_{R,min}$	0.040 for nominal bar size 8 mm to 12 mm; 0.056 for nominal bar size $> 12 \text{ mm}$	

ORDERING INFORMATION

AC200+

Part No.	Description	Box qty.
AC200-PWR	410ml hybrid injection adhesive anchoring system	6



Mixing nozzles

Part No.	Description	Box qty.
DFC1640550	Mixing nozzle - 19 element	1
MNEXT-PWR	Mixing nozzle extension (200mm)	10
AEXTN-PWR	Mixing nozzle extension (1000mm)	10



DFC1640550



MNEXT-PWR

Cartridge guns

Part No.	Description	Box qty.
CG380KF2-PWR	Cartridge gun for 420ml co-axial 10:1 cartridge	1
CGPRO-PWR	4 In 1 injection tool	1
CGB410-PWR	Battery tool for 420ml cartridge	1



CG380KF2-PWR

CGPRO-PWR



CGB410-PWR

Accessories

Part No.	Description	Box qty.
BLOWPUMP-PWR	Blow pump	1
PAWB10-PWR	SDS-Plus premium adhesive wire brush 12mm	1
PAWB12-PWR	SDS-Plus premium adhesive wire brush 14mm	1
PAWB14-PWR	SDS-Plus premium adhesive wire brush 16mm	1
PAWB16-PWR	SDS-Plus premium adhesive wire brush 18mm	1
PAWB18-PWR	SDS-Plus premium adhesive wire brush 20mm	1
PAWB20-PWR	SDS-Plus premium adhesive wire brush 22mm	1
PAWB22-PWR	SDS-Plus premium adhesive wire brush 24mm	1
PAWB25-PWR	SDS-Plus premium adhesive wire brush 27mm	1
PAWB28-PWR	SDS-Plus premium adhesive wire brush 30mm	1
PAWB30-PWR	SDS-Plus premium adhesive wire brush 32mm	1
PAWB32-PWR	SDS-Plus premium adhesive wire brush 34mm	1
PAWB35-PWR	SDS-Plus premium adhesive wire brush 37mm	1
PAWB40-PWR	SDS-Plus premium adhesive wire brush 42mm	1
PAWBHANDLE-PWR	Premium steel brush - wooden handle	1
PAWBSDM8-PWR	Premium steel brush - SDS Plus adapter	1
PAWBEXTM8-PWR	Premium steel brush - SDS Plus extension	1
APP14-PWR	Adhesive piston plug for 14mm hole	10
APP16-PWR	Adhesive piston plug for 16mm hole	10
APP18-PWR	Adhesive piston plug for 18mm hole	10
APP20-PWR	Adhesive piston plug for 20mm hole	10
APP22-PWR	Adhesive piston plug for 22mm hole	10
APP24-PWR	Adhesive piston plug for 24mm hole	10
APP25-PWR	Adhesive piston plug for 25mm hole	10
APP28-PWR	Adhesive piston plug for 28mm hole	10
APP32-PWR	Adhesive piston plug for 32mm hole	10
APP40-PWR	Adhesive piston plug for 40mm hole	10



BLOW PUMP



STEEL BRUSH



WOODEN HANDLE



SDS ADAPTER



SDS EXTENSION



PISTON PLUG