



cooking

USAGE AND  
CARE GUIDE

PRODUCT  
CODE:

PRODUCT  
CODE:  
ECT600GS  
ECT60WCX  
ECT60GX  
ECT900GX



This manual explains the proper installation and use of your appliance, please read it carefully before using even if you are familiar with the product. The manual should be kept in a safe place for future reference. In case of failure, only the Authorized Technical Service may repair this hob. Otherwise the guarantee will be null and void.

## Warning

### General Safety

- The appliance may only be installed and connected by licensed gasfitters / authorized persons.
- Built-in appliances may only be used after they have been built in to suitable built-in units and work surfaces that meet local authority standards.
- Repairs to the appliance must only be carried out by trained registered authorized service persons / engineers.
- The technical and identification data for the hob is located on the reference data plate fixed to the underside of the appliance.
- This reference data plate must be consulted before making the electrical connections.
- The electrical connections must be made by specialist installers to the legal and regulatory requirements in each country.
- If the cable is damaged in any way it must be replaced by the manufacturer or after sale service or by authorized technical staff, to avoid hazard.
- **DO NOT USE OR STORE FLAMMABLE MATERIALS NEAR THIS APPLIANCE.**
- **DO NOT SPRAY AEROSOLS IN THE VICINITY OF THIS APPLIANCE WHILE IT IS IN OPERATION.**
- **DO NOT MODIFY THIS APPLIANCE.**
- **DO NOT USE THIS APPLIANCE AS A SPACE HEATER.**
- **DO NOT PUT COMBUSTIBLE MATERIAL IMMEDIATE SURROUNDS OF THE APPLIANCE.**

### Correct Use

- People (including children) who, because of their physical, sensory or mental capabilities or their inexperience or ignorance are not able to use the device safely, should not use this device without supervision or instruction by a responsible person.
- This appliance should be used only for normal domestic cooking and frying of food.
- The appliance must not be used as a work surface or as a storage surface.
- Additions or modifications to the appliance are not permitted.
- Do not place or store flammable liquids, highly inflammable materials or fusible objects (e.g. plastic film, plastic, aluminum) on or near the appliance.
- Do not heat an empty pan on the appliance.

## Children's Safety

- The cooking zones will become hot when you cook. Therefore, always keep small children away from the appliance.
- The appliance is not intended for use by young children or infirm persons without supervision.
- Young children should be supervised to ensure that they do not play with the appliance.

## Safety During Use

- There is the risk of burns from the appliance if used carelessly.
- Cables from electrical appliances must not touch the hot surface of the appliance or hot cookware.
- Overheated fats and oils can ignite very quickly. Warning! Fire hazard!
- Switch the cooking zones off after each use.
- Users with implanted pacemakers should keep their upper body at least 30 cm from cooking zones that are switched on.
- Risk of burns! Do not place objects made of metal, such as knives, forks, spoons and saucepan lids on the cooking surface, as they can get hot.



- **Special conditions, which shall be avoided, e.g. marine environment, and any conditions necessary to ensure optimum performance.**
- **The appliances can be used in freezing conditions.**

## Safety When Installation

- DO NOT USE OR STORE FLAMMABLE MATERIALS NEAR THIS APPLIANCE.
- DO NOT SPRAY AEROSOLS IN THE VICINITY OF THIS APPLIANCE WHILE IT IS IN OPERATION.
- WHERE THIS APPLIANCE IS INSTALLED IN MARINE CRAFT OR CARAVANS, IT SHALL NOT BE USED AS A SPACE HEATER.
- This hotplate must be installed in accordance with:  
AS/NZS5601 - Gas Installations (for Australia) – current edition  
NZS 5261 – Code of Practice for the Installation of Gas Burning Appliances and Equipment (for New Zealand) This standard may not be now current!!  
Local gas fitting regulations

AS/NZS 3000 – Electrical Installations (Wiring Rules)

Building codes

Any other relevant statutory regulations.

- Check the gas type label on the underside of the hotplate, adjacent to the gas connection to ensure it corresponds to the installation gas supply. If in doubt contact the supply authority.
- The power supply cord (supplied) must not touch against any hot surfaces and must be placed so that its temperature does not exceed 75 degrees at any point along its length.
- After connecting to gas, check for leaks using soapy solution, never a naked flame.
- Where a flexible hose assembly is used, ensure it is approved to AS/NZS 1869, Class B 10mm diameter and no more than 1.0metre in length. Any hose assembly used must be restrained from accidental contact with the flue outlet of an under bench oven.

## How To Avoid Damage To The Appliance

- Do not use the cooking zones with empty cookware or without cookware.
- The ventilation gap of 5mm between the worktop and front of the unit underneath it must not be covered.
- DO NOT MODIFY THIS APPLIANCE.

## Safety When Cleaning

- For cleaning, the appliance must be switched off and cooled down.
- For safety reasons, the cleaning of the appliance with steam jet or high pressure cleaning equipment is not permitted.

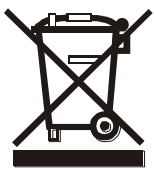

## Disposing Of The Device



When disposing of the device, do not bring it to regular municipal waste containers. Instead, bring it to electrical and electronic waste recycling and reuse center. A relevant label has been put on the device, its instructions manual, or the package. The device has been manufactured of recyclable material. By bringing the old device to recycling collection center, you show that you care about nature. Ask your local environmental care authority for information on location of such facilities.

Gas type label nearby the gas inlet, black color for natural gas, signal red color for ULPG:



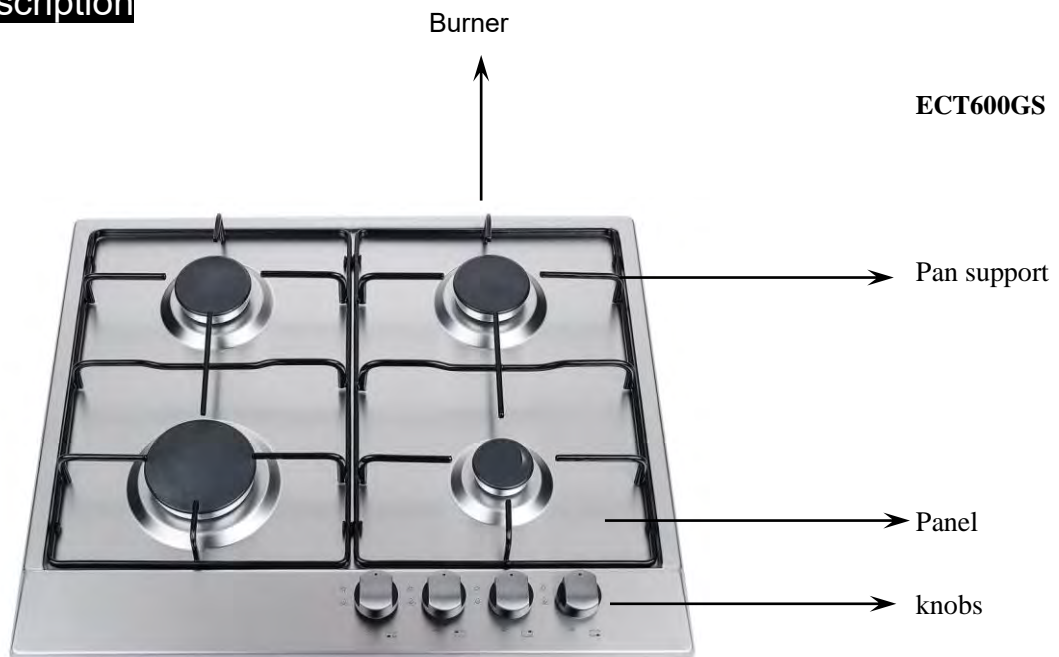

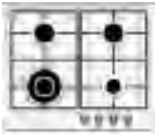
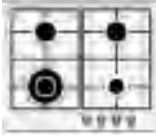
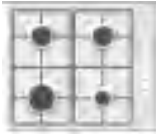

## Product Description

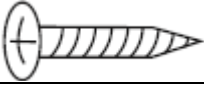

No	Model	Burner*	FSD	Pan supports	Knob position	Total gas consumption	Over view
1	ECT600GS	1W+2SR+1A	With	Enamel	Front	LPG: 27.5MJ/h	
						NG: 26.0MJ/h	
2	ECT60WCX	1W+2SR+1A	With	Cast iron	Front	LPG: 30.5MJ/h	
						NG: 29.5MJ/h	
3	ECT60GS	1R+2SR+1A	With	Cast iron	Right	LPG: 30.5MJ/h	
						NG: 29.5MJ/h	
4	ECT900GX	1W+1R+2SR+1A	With	Cast iron	Front	LPG: 39.6MJ/h	
						NG: 39.0MJ/h	

\*Note:

For burner: W=Triple Ring Wok burner, R=Rapid burner, SR=Semi-Rapid burner, A=Auxiliary burner

Accessory Name	Picture ( for reference only, physical unit maybe different)	Quantity
User Manual		1
Sealing tape		1 roll
Additional labels	You have additional rating label in accessory bag, suggest attach it onto a surface where it can be read e.g. inside surface of adjacent cupboard	1 set
Installation clip		4 sets
Screws ST4.2x24		4 pcs
LPG Injectors		4 pcs
Elbow & Washers		1 Elbow, 3 washers
Natural gas regulator		1

## Technical Specifications

Model	Product Dimensions (h x w x d) mm	Cut-out Size ( w x d)mm	Electrical Connection	Rated Input Power
ECT60WCX	85x580x500	552 x 470	220-240V/50Hz	0.5W
ECT600GS	85x580x500	552 x 470	220-240V/50Hz	0.5W
ECT60GX	85x580x500	552 x 470	220-240V/50Hz	0.5W
ECT900GX	85x860x500	827 x 470	220-240V/50Hz	0.5W

# Installation

## **Before Installation:**

- Before cutting into any bench tops, ensure the minimum clearances to walls, adjacent surfaces and overhead surfaces required by the relevant gas appliance installation code (see above) will comply. Dimensions are specified in millimeters (mm)  
Overhead cupboards and range hood = 650 mm.  
Side and rear clearance = 200 mm to any burner edge.  
Overhead exhaust/ceiling fan = 750 mm  
Horizontal surfaces adjacent the hob = less than or equal to the hob height.  
Ensure there is sufficient clearance to fit the regulator and/or flexible hose connection with the hotplate in the installed position.  
Before the appliance is installed into the cabinet, please make sure any transit protection is removed.

## **When you have installed the hob, make sure that**

- The GPO (general purpose outlet) must always be in an accessible position.
- The supply connection point, test point and natural gas regulator adjustment screw (for Natural gas installation) are accessible for testing and/or adjustment with the hotplate in the installed position.

**TO BE INSTALLED ONLY BY AN AUTHORIZED PERSON.**

### 1. **Cupboard Cutting**

Bench top thickness, 30– 40 mm (3 – 4 cm).

**Model: ECT60WCX, ECT600GS, ECT60GX**

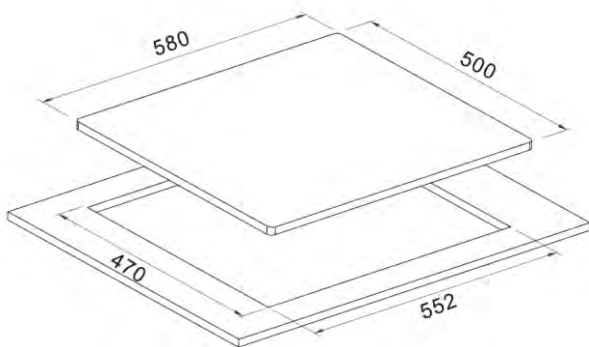

**Model: ECT900GX**

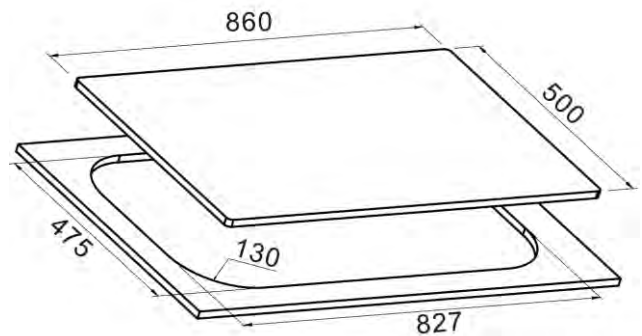



## 2. Place Burner Box

Apply the adhesive sealing tape to the underside lip of the burner box. Shown at G opposite. Place burner box into cutout hole and fit clamping brackets to clamp the hotplate to the bench.

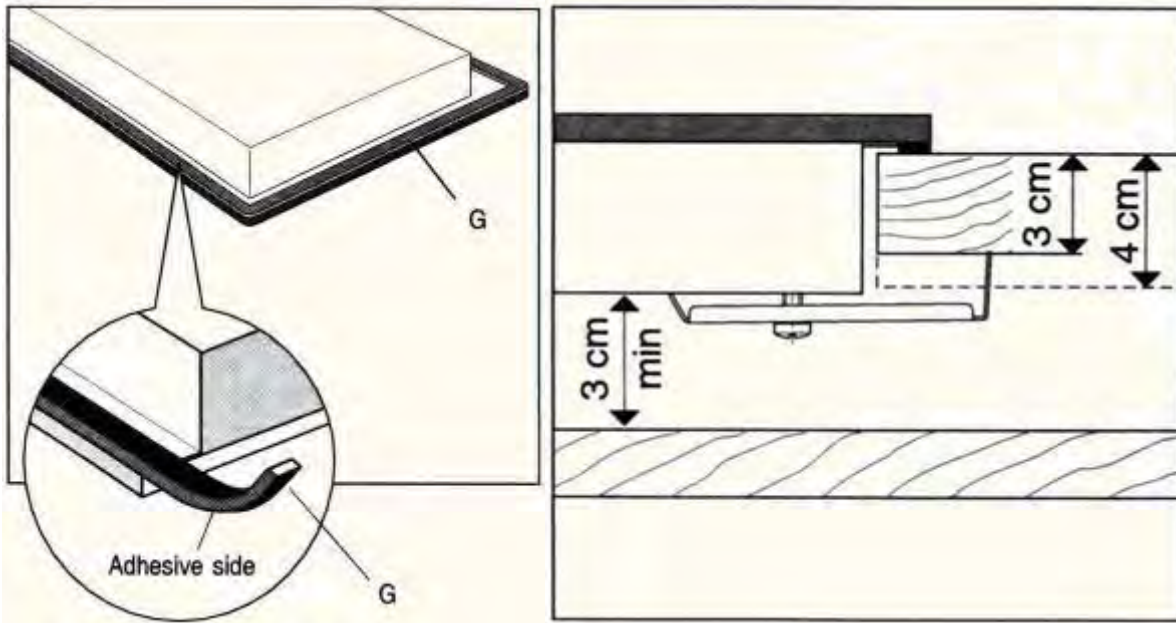

## 3. Fit Burners And Trivet.

Replace burners and ensure they are correctly repositioned over the ignitor (S) and thermocouple (T). The ignitor (S) must be clean for trouble free sparking. Test burner ignition and burner flame for correct operation, If burner is placed correctly it will not rotate on its supports. The Triple Ring (Wok) burner (diagrams below) does not fit over the ignitor or thermocouple but must be placed on its supports. Make sure trivet is fitted onto its locator on burners and can't rotate after assembled.

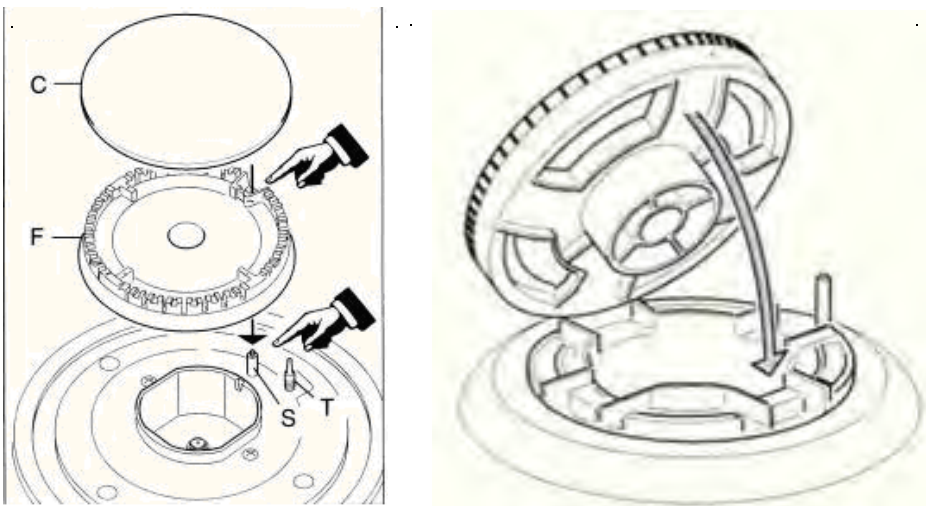

## 3. Electrical Connection

Install a 10 amp general purpose outlet (GPO) in accordance with relevant electrical standards and/or codes of practice applicable. The power supply cord (supplied) must not touch against any hot surfaces and must be placed so that its temperature does not exceed 75 °C at any point along its length.



After having installed the hotplate, the GPO must always be in an accessible position.

**ECT60WCX , ECT600GS, ECT60GX**

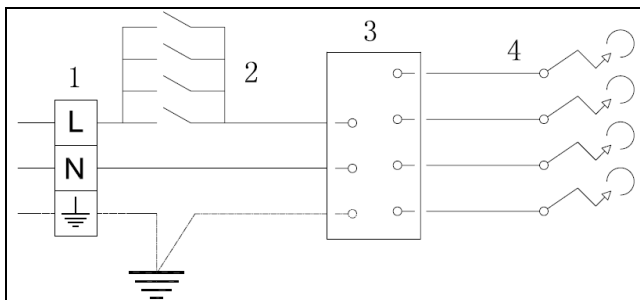

**ECT900GX**

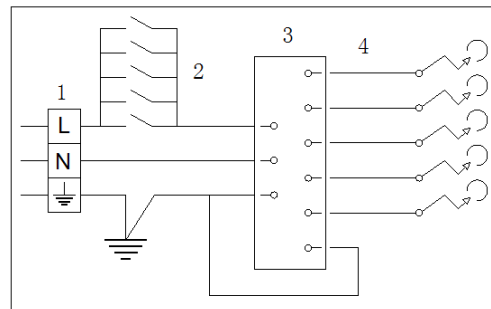

**Wiring diagram**

**4. Gas Connection**

Install in accordance with relevant gas standards and/or codes of practice applicable.

Connect the elbow fitting to the appliance gas manifold connection, and check that seals between the elbow and manifold connection are in place and in good condition.

- For Natural gas: connect the natural gas appliance regulator (pictured opposite) with integral test point using approved gas thread tape or compound to the elbow fitting.
- For Universal LPG: see page 9



Ensure the supply connection point, test point and natural gas regulator adjustment screw (for Natural gas installation) are accessible for testing and/or adjustment with the hotplate in the installed position.

Where a flexible hose assembly is used, ensure it is approved to AS/NZS 1869, Class B. Any hose assembly used must be restrained from accidental contact with the flue outlet of an under bench oven.

This hose assembly shall be suitable for connection to a fixed consumer piping outlet located as follows:

Hotplates at a point 800 mm to 850 mm above the floor and in the region outside the width of the appliance to a distance of 250 mm.

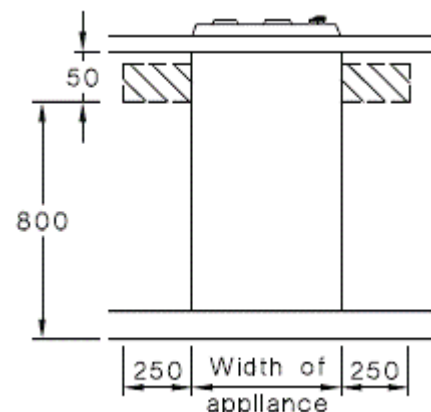

After connecting to gas, check for leaks using soapy solution, never a naked flame.



Inlet connection region for flexible hose

Fit the duplicate data plate (supplied in separate bag) on a surface adjacent to the hotplate, for example, the inside of the cupboard door so it is clearly visible for any service technician.

**SETTING THE GAS PRESSURE:**

Fit a manometer with a 6 mm rubber hose to the test point on the regulator (for natural gas).

Light Triple Ring and Auxiliary burner on and adjust test point pressure to 1.00 kPa. Turn the two burners off and on again and recheck the pressure is same as set previously or adjust as required.

**TEST FOR CORRECT OPERATION:**

After installation and adjusting burner pressure using test point, each burner ignition and operation must be tested individually and with all burners operating. This testing must be done by the installer before leaving.

## Natural Gas (the appliance test point is located at the regulator)

The supplied regulator must be fitted to the appliance inlet connection. Gas pressure must be adjusted to 1.0 kPa when approximately 50% of the burners are on high flame.

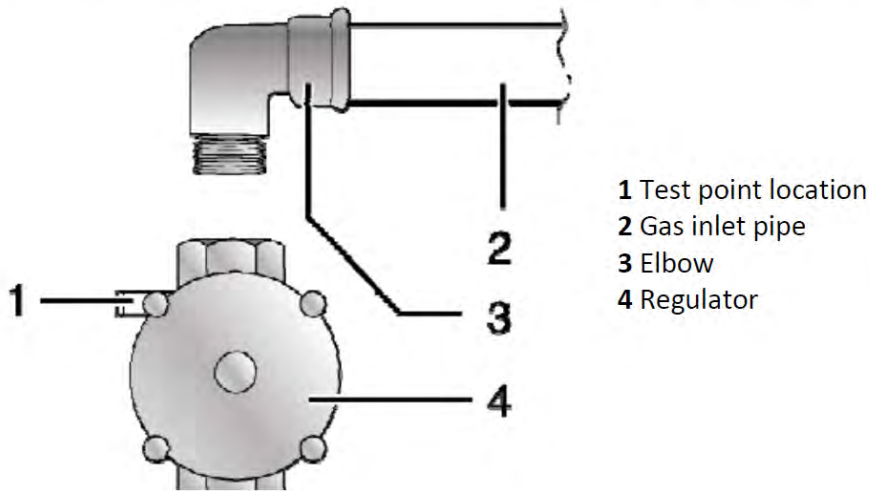

## Universal LPG (the appliance test point is located at the injector)

Gas pressure must be checked to confirm the appliance operating pressure is 2.75 kPa, the appliance test point is the rapid burner injector as shown below.

1. Disconnect power.
2. Light the auxiliary burner and set to high flame. Ensure all other burners are off.
3. Zero manometer, then apply flexible tubing to seal over the Rapid burner injector, hold securely in place and check the gas pressure by pressing in the corresponding burner control knob in, then turning to high flame position.
4. If the pressure is 2.75 kPa, reassemble the burner and perform the final checks as per this instruction manual.
5. If the pressure is **not** 2.75 kPa, disconnect the appliance and check/adjust/replace the LPG cylinder regulator(s) as appropriate in accordance with AS/NZS 5601

*Patent 2015101170. For enquires contact Gas Approval Consulting Pty Ltd  
Tinnon licence 036 for SAI-400193*



*Patent 2015101170. For enquires contact Gas Approval Consulting Pty Ltd*

**Alternative:** If the appliance is supplied with an LPG test point adapter; then this component maybe fitted to the inlet connection for the purpose of a test point.

## ADJUSTING THE BURNER MINIMUM FLAME HEIGHT:

NOTE: This adjustment can only be performed by the installer or an authorised service personnel.

The minimum burner flame is factory adjusted for the gas type stated on the gas type label adjacent to the gas connection and should not require adjustment. Adjustment may be required if the hotplate has been converted from Natural gas to Universal LPG or vice versa.

### GAS CONVERSION INSTRUCTIONS:

The manufacturers servicing instructions detail how authorised personnel may convert the hotplate from Natural gas to Universal LPG or from Universal LPG to Natural gas. Contact the manufacturer or agent as required.

#### For model ECT60WCX , ECT600GS , ECT60GX

ADJUSTED FOR NATURAL GAS 1.0kPa		
NOZZLES DIAMETER	mm	Gas consumption, MJ/h
WOK	1.70	13.0
Rapid	1.40	9.5
SEMI RAPID	1.10	6.0
AUXILIARY	0.90	4.5
Replacement of the nozzles must be performed by a qualified person. Once the nozzles have been replaced this label must to be affixed to the name plate of the appliances.		
Natural Gas regulator is to be fitted and adjusted		

ADJUSTED FOR ULPG 2.75KPa		
NOZZLES DIAMETER	mm	Gas consumption, MJ/h
WOK	0.98	13.0
Rapid	0.90	10.0
SEMI RAPID	0.7	6.75
AUXILIARY	0.55	4.0
Replacement of the nozzles must be performed by a qualified person. Once the nozzles have been replaced this label must to be affixed to the name plate of the appliances.		
Change the NG regulator to LPG by a qualified person.		

#### For model ECT900GX

ADJUSTED FOR NATURAL GAS 1.0kPa		
NOZZLES DIAMETER	mm	Gas consumption, MJ/h
WOK	1.70	13.0
Rapid	1.40	10.0
SEMI RAPID	1.10	6.0
AUXILIARY	0.90	4.0
Replacement of the nozzles must be performed by a qualified person. Once the nozzles have been replaced this label must to be affixed to the name plate of the appliances.		
Natural Gas regulator is to be fitted and adjusted		

ADJUSTED FOR ULPG 2.75KPa		
NOZZLES DIAMETER	mm	Gas consumption, MJ/h
WOK	0.98	13.0
Rapid	0.90	10.0
SEMI RAPID	0.7	6.3
AUXILIARY	0.55	4.0
Replacement of the nozzles must be performed by a qualified person. Once the nozzles have been replaced this label must to be affixed to the name plate of the appliances.		
Change the NG regulator to LPG by a qualified person.		

## Start Using Your Appliance

ECT60WCX, ECT600GS,

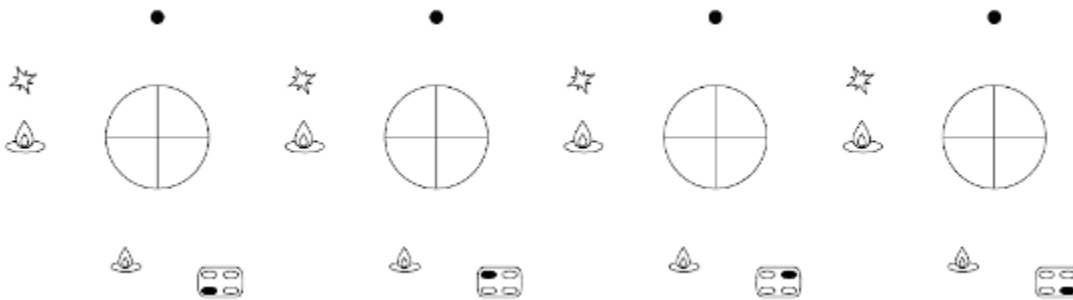

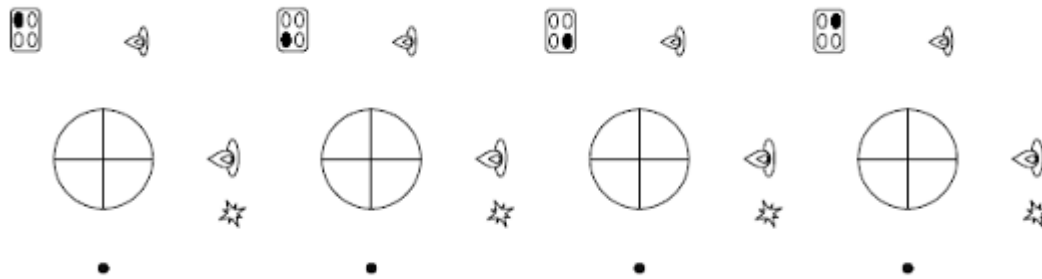

## ECT60GX

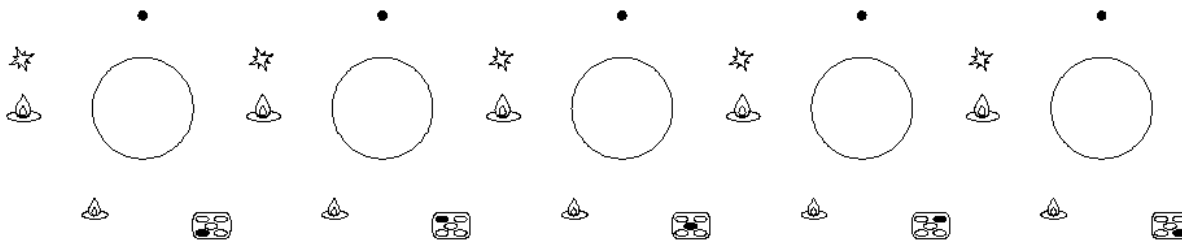

## ECT900GX



Description	Explanation
 Zone indicators	These show which zone is under control.
Flame power	Flame power of the zones,  is the lowest and  is the highest.

The hotplates are fitted with mains powered electronic spark ignitors, so must be connected to mains power supply (i.e. nominal 220~240 V ac) to operate. If power is not available, the hotplate will still work but the burners will have to be lit with a match or similar.

Depressing the gas control knob of any burner will activate the spark ignition for all burners. To light the burner, turn the gas control knob to the High Flame setting of the burner to be lit, while at the same time depressing the gas control knob to activate the spark ignition. Once the burner is alight continue to depress the gas control knob for 5 – 10 seconds to allow the flame safeguard to activate. If when you release the gas control knob, the burner flame goes out the flame safeguard has not heated up enough so repeat the ignition procedure after waiting 1 minute for gas to disperse. If problems with burner lighting persist, refer to the TROUBLESHOOTING section of these instructions.

If power is not available, light a match or similar, then turn the gas control knob for the burner to be lit, to the High Flame setting. Once again if problems with burner lighting persist, refer to the TROUBLESHOOTING section of these instructions.

When burner lights, adjust desired flame height. On finishing, turn control knob to off position marked with a black DOT.

## **BURNER AND UTENSIL CHOICE**

The **maximum** utensil (pan) diameters in millimeters

---

(mm) for each burner are:

1. For Natural Gas hotplates

Auxiliary (small) and Semi-Rapid (medium) =  
195 mm  
Rapid (large) = 230 mm  
Triple ring (wok) = 270 mm

2. For Universal LPG hotplates

Auxiliary (small), Semi-Rapid (medium) and  
Rapid (large) = 195 mm  
Triple ring (wok) = 230 mm

The **minimum** utensil (pan) diameters in millimeters  
(mm) for each burner are:

Auxiliary (small) = 80 mm  
and Semi-Rapid (medium) = 140 mm  
Rapid (large) and Triple ring (wok) = 195 mm

For best efficiency and to ensure utensil handle does not overheat, place the utensil centrally on the burner and adjust the flame height so all the flame remains under the utensil.

## Maintenance & Troubleshoot

Cleaning and maintenance should be carried out with the appliance cold especially when cleaning the enameled parts. Avoid leaving alkaline or acid substances (lemon juice, vinegar etc.) on the surfaces.

### STAINLESS STEEL

The stainless steel hob of the hotplate must be cleaned regularly (e.g. weekly) to ensure long life expectancy of the hotplate.

Ensure hotplate has cooled. Wash down with warm soapy water and rinse with clean water.

Dry with a clean soft cloth. A specialized stainless steel cleaning fluid may be used.

NOTE: Ensure that wiping is done along with the grain of the stainless steel to prevent any unsightly crisscross scratching patterns from appearing.

### TRIVETS (UTENSIL SUPPORTS)

Enameled parts must only be washed with a sponge and soapy water or with non-abrasive products. Rinse with clean water. Dry with a clean soft cloth.

### BURNERS

Remove trivets from hob. Ensure burners are cool. Remove the burners enameled cap (C) and aluminum burner crown (F).

Wash down with warm soapy water and rinse with clean water. Dry with a clean soft cloth.

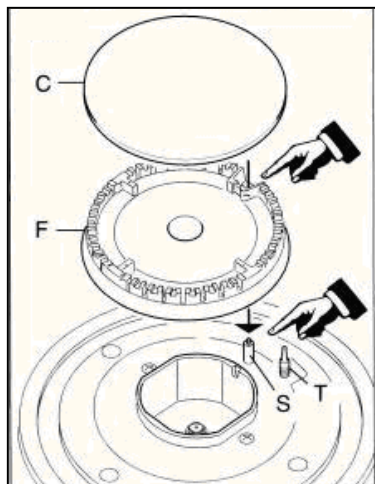

Use a cotton bud, tooth brush, or some other item to clean out any incrustations or dirt from the four holes marked (H)

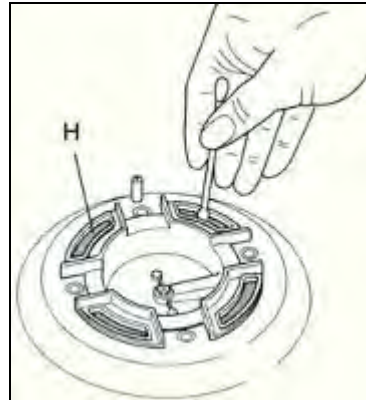

Replace burners and ensure they are correctly repositioned over the igniter (S) and thermocouple (T). The igniter (S) must be clean for trouble free sparking. Test burner ignition and burner flame for correct operation.

The Triple Ring (Wok) burner (diagrams below) does not fit over the igniter or thermocouple but must be placed on its supports. If burner is placed correctly it will not rotate on its supports.

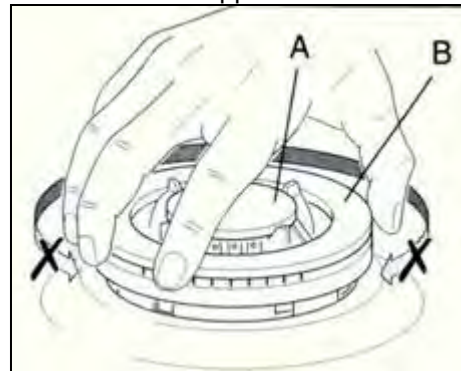

- (b) removal of components for service—
  - (ii) pilot and flame safeguard;
  - (iii) ignition system;
  - (v) gas control;
  - (vii) hotplate top;
  - (ix) thermocouple;
- (c) parts replacement—
  - (iv) electronic ignition;
- (d) adjustments—
  - (iv) ignition (spark gap);

## TROUBLESHOOTING

Servicing of the hotplates must only be done by an authorised service representative, and the hotplate must not be modified. Power must be disconnected before any servicing or maintenance is conducted.

### DO NOT MODIFY THIS APPLIANCE.

It is recommended the hotplate serviced by an authorized person at least every 2 years. This service is not covered by warranty.

Abnormal conditions include:

- Excessively yellow or sooting flame type.
- Flame lifting off the burner ports.
- Flame lighting back into the burner (normally associated with a popping sound).
- Objectionable odour of the flames combustion products.

Should a faulty condition develop in the hotplate that is not described above, refer to the following table first for possible causes and remedies prior to contacting an authorised service representative. Servicing beyond the remedies listed shall only be undertaken by an authorised service representative.

FAULT	POSSIBLE CAUSE	REMEDY
No spark when gas control knob depressed.	No power.	Check plugged in and switched on. Check mains circuit breaker.
	Loose sparker cable.	Call authorised representative.
	Burner not aligned properly.	Remove and re-fit burner.
Burner not lighting when spark ignition working.	Gas supply off.	Check gas supply valve on.
	Burner not aligned properly.	Remove and re-fit burner.
	Burner ports blocked.	Remove, clean and replace burner.
Burner goes out when control knob released.	Flame safeguard not activated.	Re-light, allow more time for flame safeguard to activate.
	Flame safeguard faulty connection or broken.	Call authorised representative.
Uneven flame pattern or slight flame lifting.	Burner ports blocked.	Remove, clean and replace burner.
At minimum flame setting the flame is too high.	Turndown control setting incorrect.	Call authorised representative.
Small flame on High setting.	Regulator faulty.	Call authorised representative.
	Gas supply pressure low.	Call authorised representative.
	Incorrect injector fitted.	Call authorised representative.
	Blocked injector or gas supply tube.	Call authorised representative.
	Incorrect utensil size.	Refer to operating instructions utensil choice.
Flame too high on High setting.	Regulator faulty.	Call authorised representative.
	Incorrect injector fitted.	Call authorised representative.
	Incorrect utensil size.	Refer to operating instructions utensil choice.







**Pronto** Service + Support: 1800 440 335  
Email: [service@eurostylegroup.com.au](mailto:service@eurostylegroup.com.au)

HEAD OFFICE

65 Glynburn Road, Glynde SA 5070

Ph: 08 8165 1012

**[www.euroappliances.com.au](http://www.euroappliances.com.au)**