

# 60cm Electric Multifunction Oven

## BUILT-IN OVEN

PRODUCT CODE: **EO60M8SX**



eurocooking



### FEATURES:

- + 9 multi-functions
- + Fully programmed electronic touch control
- + Contained cavity cooling + fan
- + Chrome push pull knobs
- + Triple glazed removable inner glass
- + Removable rack support
- + Telescopic runner
- + 2 oven shelves & 1 baking tray
- + Enamel oven interior
- + Stylish black glass finish



### 9 MULTI-FUNCTIONS:



#### CONVENTIONAL

This method of cooking provides traditional cooking with heat from the top and lower elements. Particularly suitable for traditional roasting and baking on the centre shelf only.



#### FULL GRILL

Full grill is the perfect option for quick grilling. Toast your favourite meals or finish off the tops of your recipes.



#### DEFROST

In defrost mode, no heating elements are used. Only the fan is activated to circulate air inside the oven for defrosting. It defrosts food up to 30% faster than traditional methods.



#### THERMOWAVE FAN ASSISTED

This is the position where the heat is coming from the lower and upper heating elements and the heat is circulated into the oven by the fan motor and blades.



#### OVEN LIGHT

The oven light will automatically turn on once any function is selected, helps to monitor the progress of your cooking.



#### FAN FORCED COOKING

For the ultimate roast or perfect batch of pastries. The element surrounding the fan delivers even heat for even cooking results, approx. 160°C - 180°C is recommended.



#### FAN GRILL

This function is perfect for fish, chicken Fillets or meat Cutlets. This Combination is exceptional for cooking meats such as poultry, game and roasts, making them crispy on the outside and tender in the middle. The door can be left closed whilst grilling and browning will occur from the top element.



#### BOTTOM ELEMENT

Great for pizza cooking, the bottom element creates the perfect cooking function for base cooked food.



#### TOP ELEMENT + GRILL ELEMENT

Grill or toast enough of those favourite after school snacks to feed an army with the top element function.

### SPECIFICATIONS:

#### Electrical Requirements

This oven can be connected to a 15 AMP wiring connection. For more information please refer to a qualified electrician.

#### Power Consumption

220-240v - 50/60Hz - 3.0Kw

#### Oven Volume Capacity

80 litres (gross) - 70 litres (net)

#### Weight

36.8kg (gross) - 33.3kg (net)

### PRODUCT DIMENSIONS:

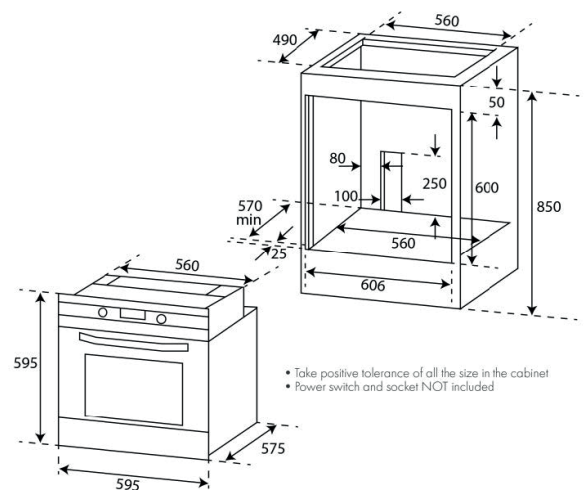

### CLEANING AND MAINTENANCE

Easy clean AAA grade enamel interior.

Clean stainless steel using only recommended stainless steel cleaning products. No abrasives, corrosive detergents, bleaches or acids not required for cleaning the oven.