

Installation instructions

Thank you for using our product. Before installation, please read this manual thoroughly to ensure correct installation. Please keep this manual handy for future reference.

VIDEO LINK



ABOUT THE PRODUCT

- The Monoflat Unizon is a coplanar sliding door system.
- Built in soft closer, enables two-way soft closing movement in both direction.

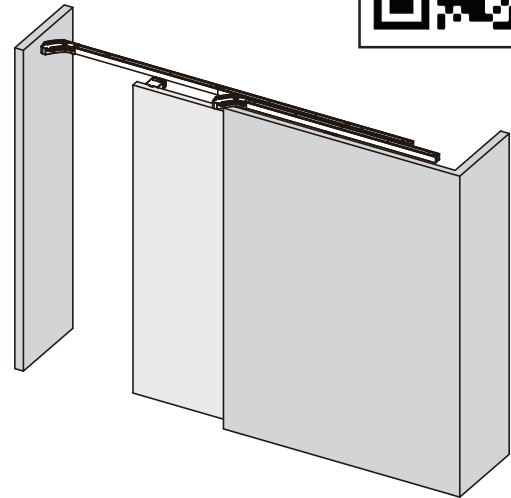
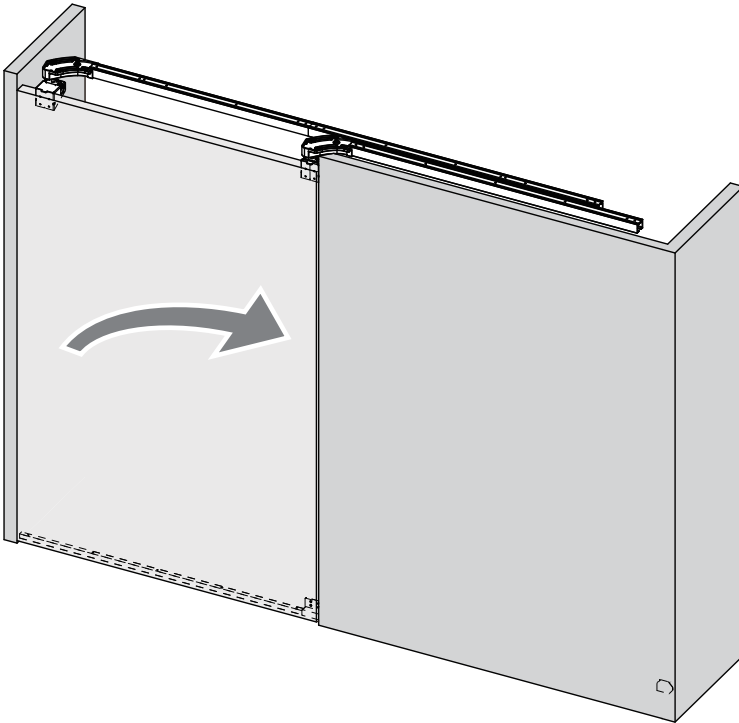

SPECIFICATION

Item Name	MFU1200-40	MFU1200-70
Door Height	MAX. 106-5/16" (2700 mm)	
Door Width	31-1/2" ~ 47-1/4" (800~1200 mm)	
Door Thickness	1-3/16" ~ 1-9/16" (30~40 mm)	
Door Weight	44 ~ 88.2 lbs 20 ~ 40 kg	88.2 ~ 154.3 lbs 40 ~ 70 kg
Adjustment Range: Vertical ±4 mm Front/Back ±4 mm		

- The recommended temperature range for use is 5°C to 40°C.
- The closing speed of the soft closing type door may change depending on the ambient temperature, operating method or installation quality.

FOR YOUR SAFETY AND PROPER INSTALLATION









Meaning of symbols Warning Caution Prohibited Required

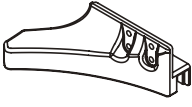
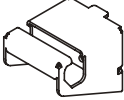
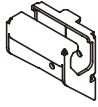
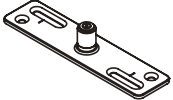
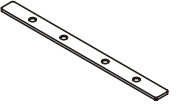
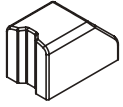
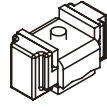
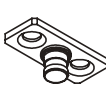

Warning: May result in serious injury if not followed properly.

- This product should be installed by a qualified person in accordance with this manual. If it is not installed correctly, the door may fall and cause injury.
 - Provide a frame that can withstand the weight and impact of opening and closing the door. Be sure to use the specified screws and tighten them securely. If the mounting strength is insufficient, the door may fall and cause injury.
 - Do not use this product for any other purpose, or with doors that are outside the specifications of this manual.
 - Do not disassemble or modify any parts other than those described in this document.
-
- This product is a part for architectural fittings. Please check the function and safety of the final product. Inform the end user how to use product safely.
 - Follow the specified dimensions, specifications, and alignment of the door and frame. Warping, tilting or twisting of the frame or door may cause failure.
 - If cutting any parts, make sure to remove any burrs before installation. Also check the upper track for any left-over burrs or scraps and remove these.
 - Make sure to check the screws for slack at regular intervals (one month from first usage, half a year, and then one time every years is recommended).
 - We recommend that two or more people install this product to reduce the risk of damaging components.

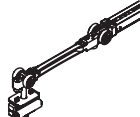

PARTS LIST

Left opening is shown in the parts list and the installation drawing.

Set name		Item name		
Bracket set Left to Right opening		MFU1200-L-BL		
Bracket set Right to Left opening		MFU1200-R-BL		
As for right opening, ① and ② will be mirror image.				
① Guiding track (top)	② Guiding track (bottom)	③ Bracket (for leading edge)	④ Bracket (for trailing edge)	⑤ Bottom guide
 x2	 x1	 x1	 x1	 x1
⑥ Connecting plate	⑦ Door stopper (floor)	⑧ Bumper block	⑨ Trigger	⑩ Jig
 x1	 x1	 x1	 x2	 x1
⑪ Bind head tapping screw 5x40	⑫ Countersunk head tapping screw 4x40	⑬ Countersunk head tapping screw 4x20(Black)	⑭ Countersunk head tapping screw 4x30(φ6 head)	
For ①  x10	For ⑥  x4	For ⑤  x4	For ⑨  x4	
⑮ Bind head tapping screw 5x20	⑯ Pan head tapping screw 4x30	⑰ Caution sticker		
For ②③④  x12	For ⑦  x3	 x1		

Set name	Item name	⑱ Soft closer(leading edge)	⑲ Door roller(trailing edge)
Closer set 40kg	MFU1200-40DSC-BL	 x1	 x1
Closer set 70kg	MFU1200-70DSC-BL		

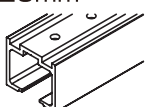
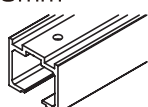
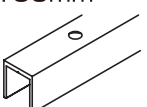
※1 Do not remove the tape on the product.

Set name	Item name			
Rail set	MFU1200-RS-BL			
⑳ Upper track A	㉑ Upper track B	㉒ Bottom track	㉓ Bind head tapping screw 5x40	㉔ Countersunk head tapping screw 4x20
1120mm  x2	850mm  x1	1100mm  x1	For ㉑㉒  x15	For ㉔  x5

■ Tools needed
 Phillips screwdriver : # 2 
 Hex key(3mm、4mm) 
 Spanner wrench(13mm) 
 Support 

■ Cover panel

Cover panels	Height	Width	Thickness
Front cover panel	60	Opening width	MAX. 13
Rear cover panel	60	FREE	FREE

INSTALLATION DRAWING

Units: mm

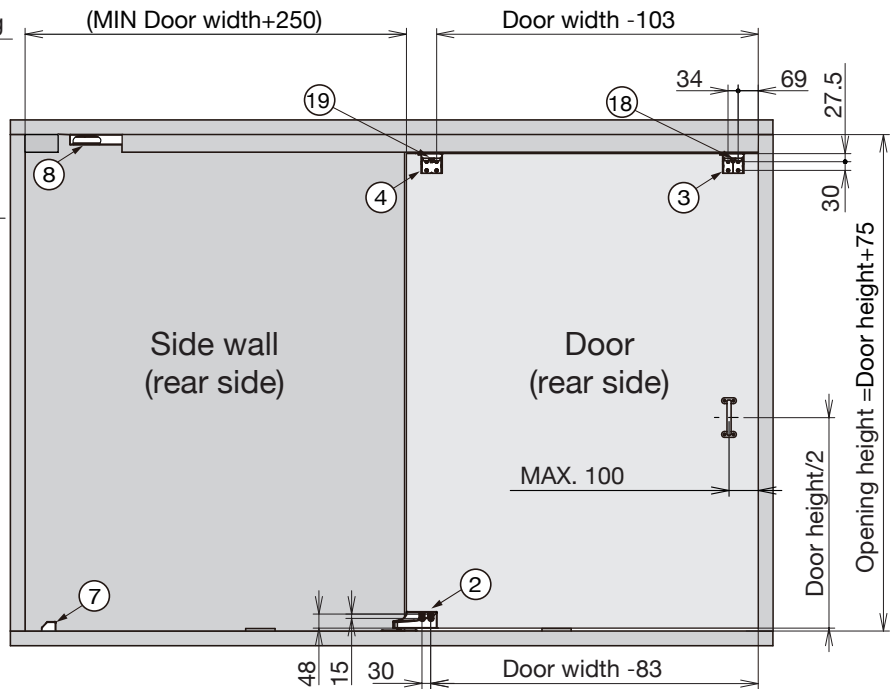
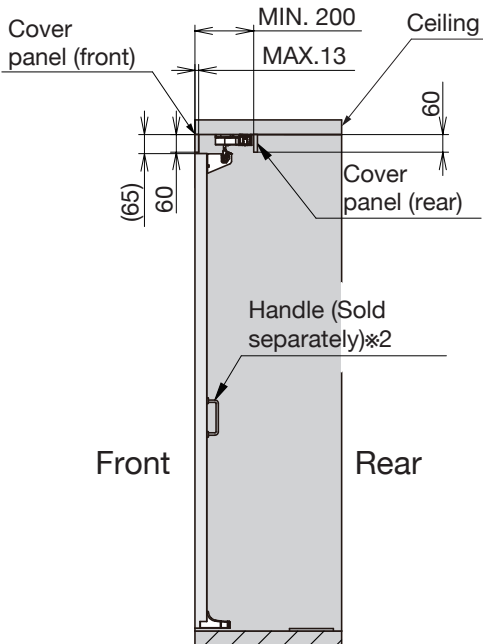
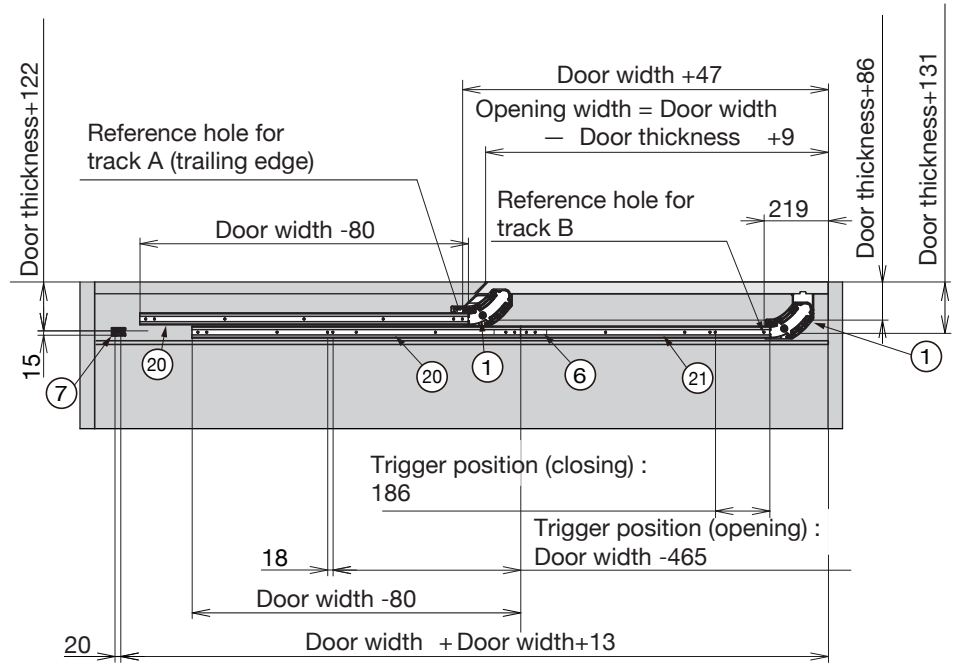
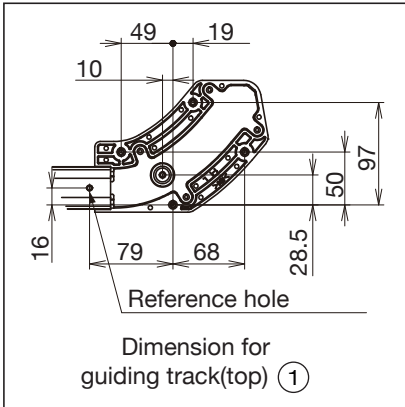
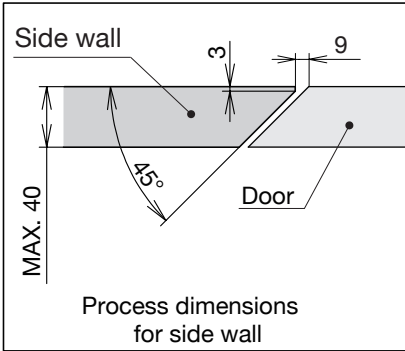

*2 Handle is necessary to open/close the door from rear side.

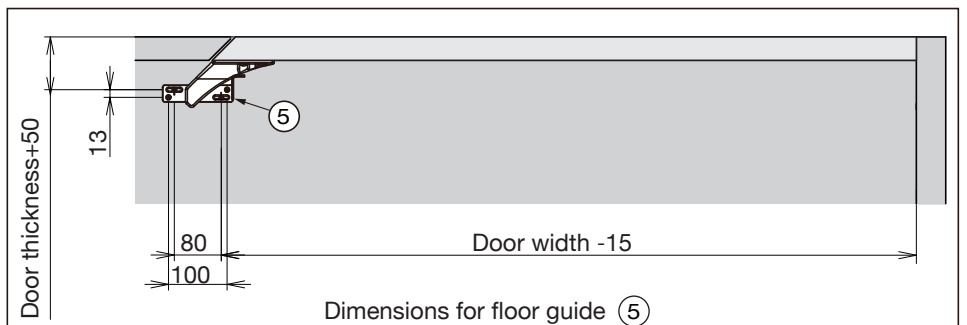
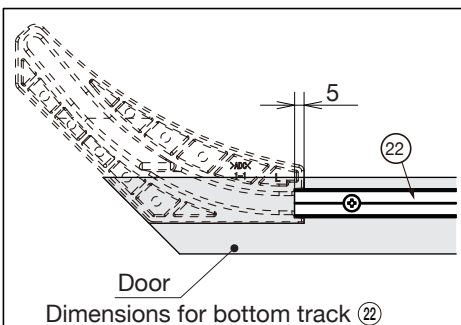

CAUTION

If door is warped or the mounting position of the parts is incorrect, it will not be flat with the side wall when the door position is adjusted,

DOOR PROCESS DIMENSIONS

The below drawing shows the left to right opening type.

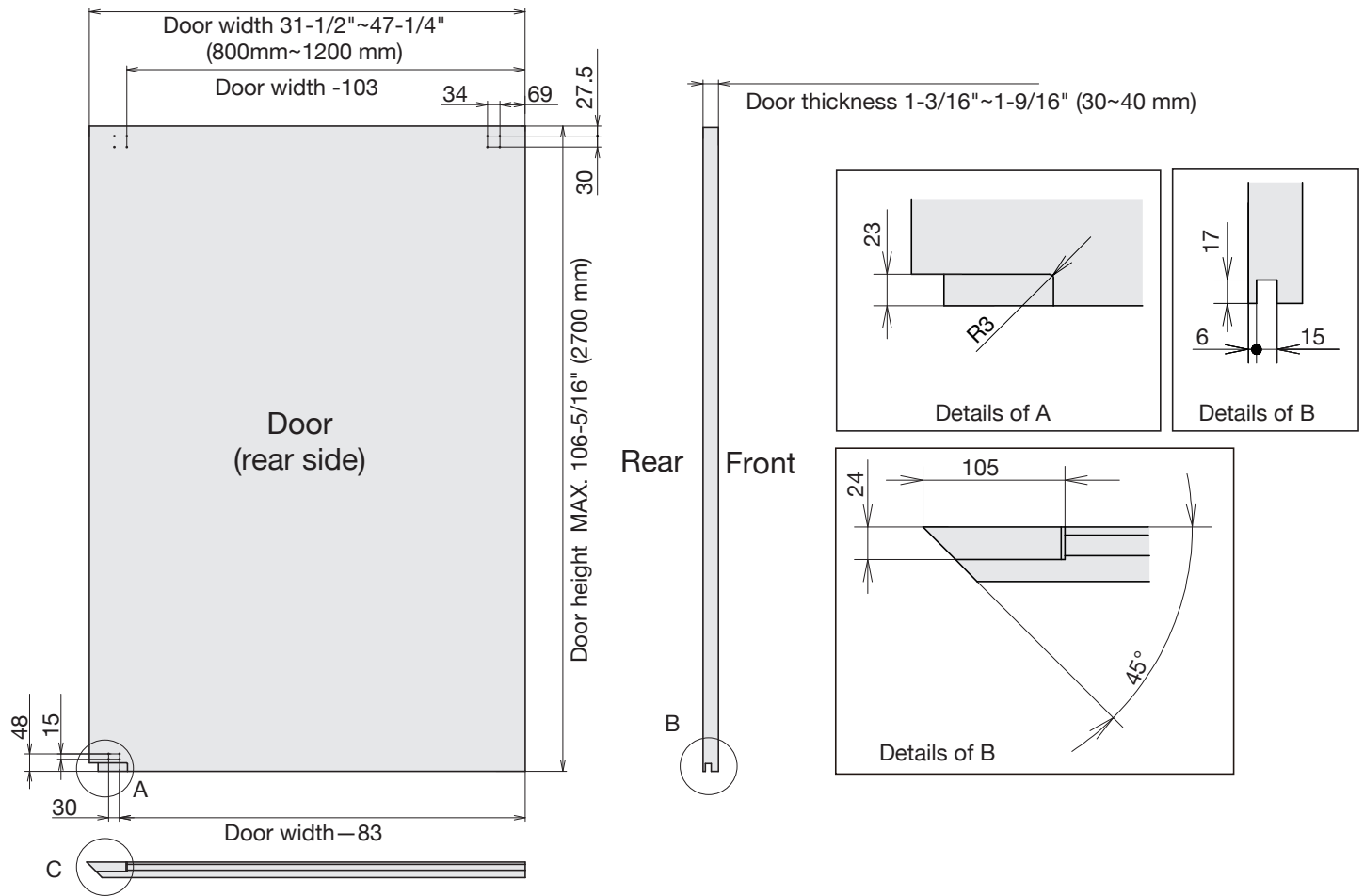

INSTALLATION

A left to right opening door is used as an example.

1 Cutting Track and Hole Drilling on Upper Track

*3 No need to process the track if its length is 47-1/4" (1200 mm).

CAUTION

- ❗ When cutting, reinforce the track to prevent deformation at the cut section.
- ⊘ Do not process upper track B.

■ (20) Upper track A (leading edge)

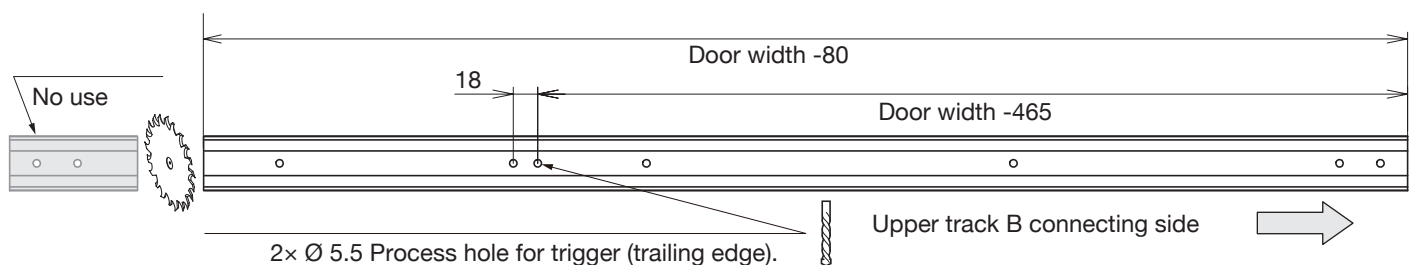

3 Mounting of Upper Track B and Connecting Plate

⚠ CAUTION

❗ Remove any dirt or aluminum chips from the track.

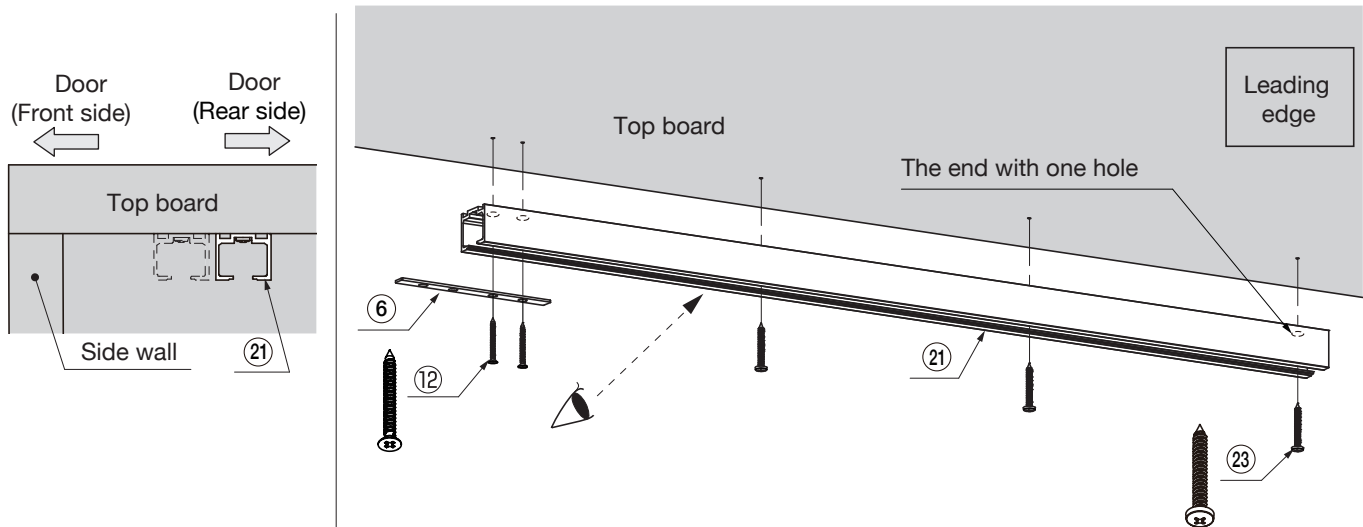

4 Verification Before Installing the Soft Closer

⚠ CAUTION

⚠ Without verification the self closing feature may fail.

OK

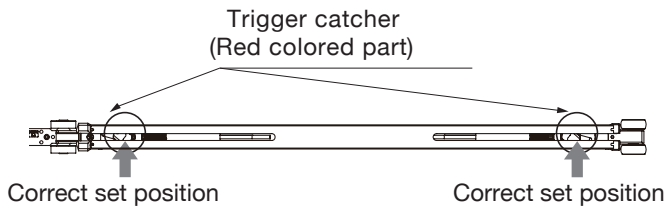

X

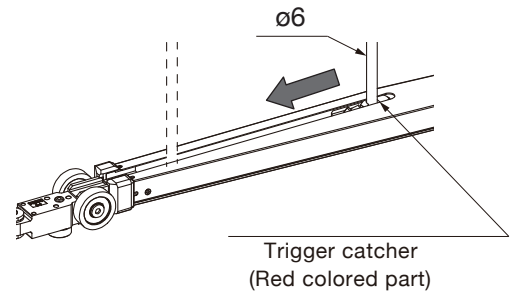
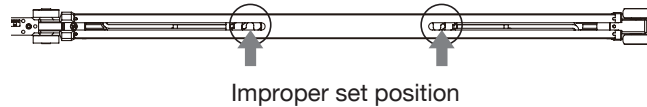

If the trigger position is wrong, pull back the trigger catcher to the correct position using a 6mm diameter round bar.

5 Inserting Soft Closer into Upper Track B

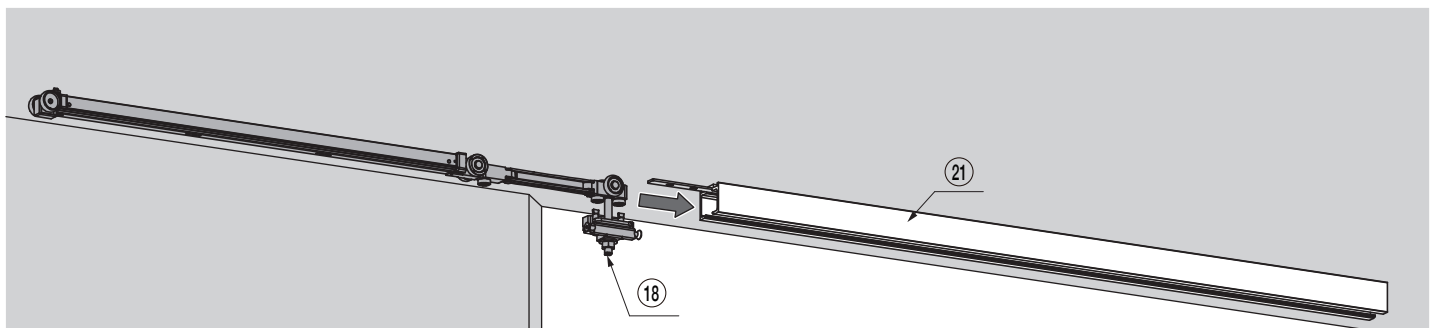

6 Mounting of Upper Track A

- (20) Upper track A (leading edge)

1

⚠ CAUTION

- ❗ Remove any dirt or aluminum chips from the track.

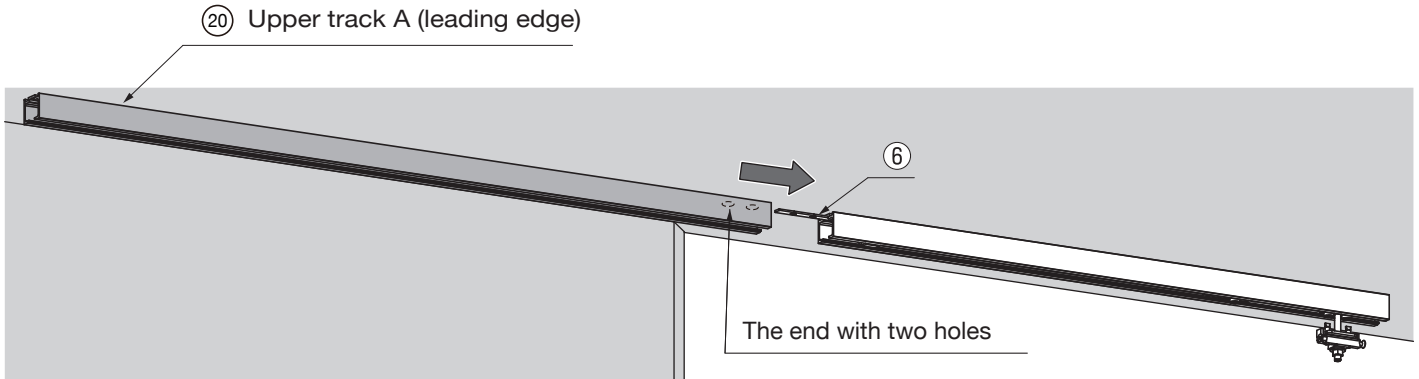

2

⚠ 注意 CAUTION

- ❗ Keep holding the track until screwing is finished.
- ❗ Be careful not to misalign the tracks. Tighten the screws firmly to leave no gap.

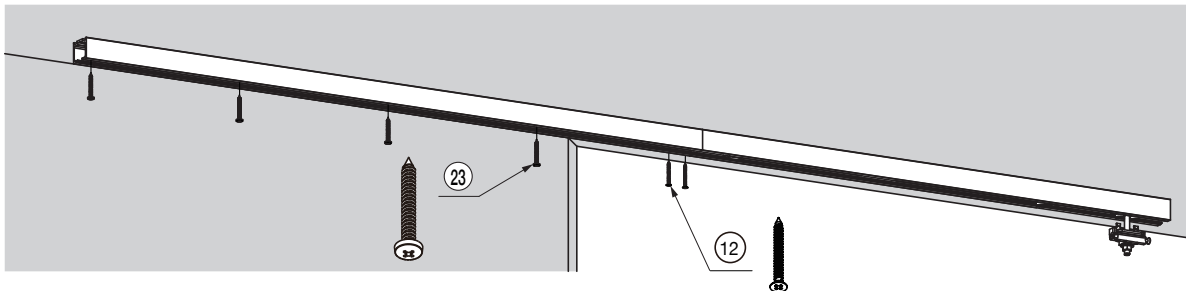
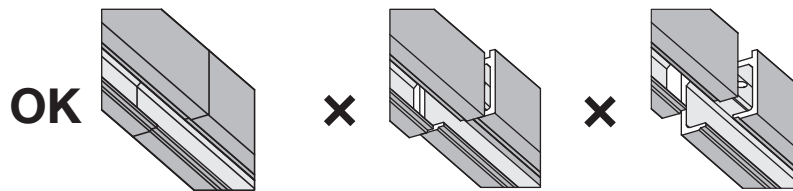

- (20) Upper track A (trailing edge)

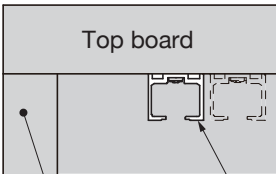
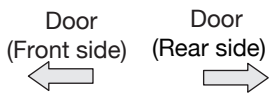

- (20) Upper track A (trailing edge)

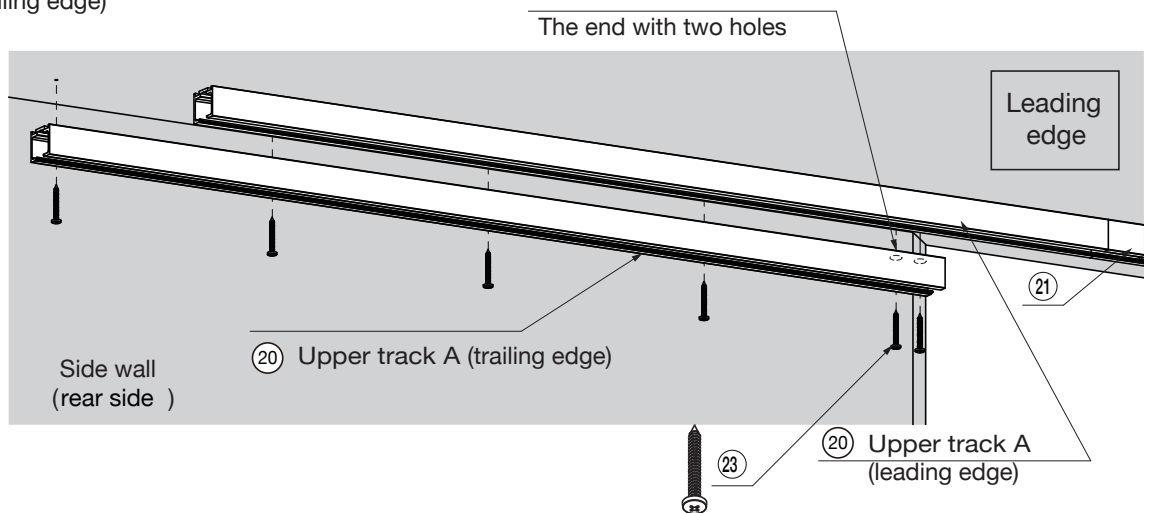

7 Mounting of Guiding Track (top)

1 CAUTION

 Be careful not to misalign the tracks. Tighten the screws firmly to leave no gap.

OK

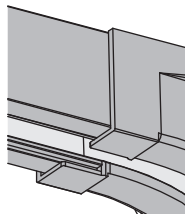

X

Gap

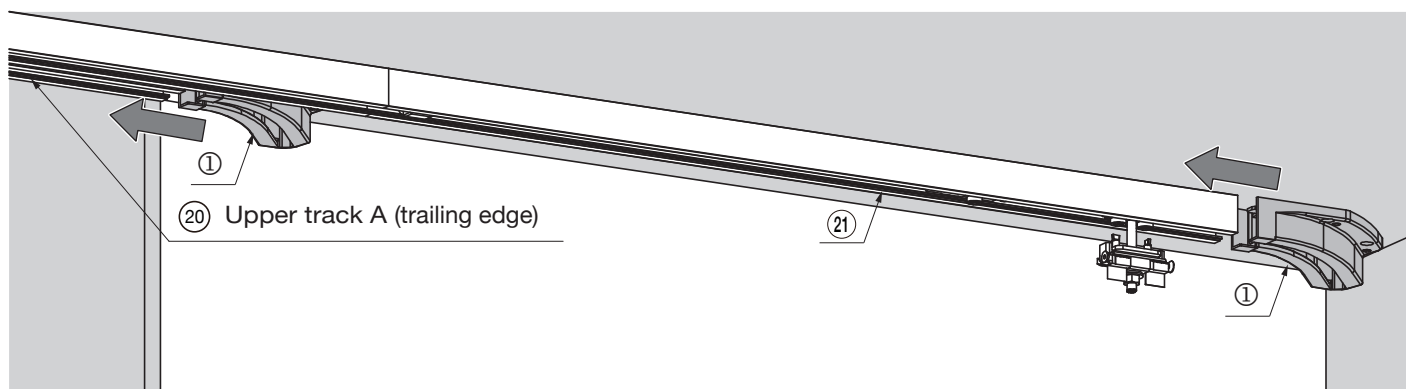
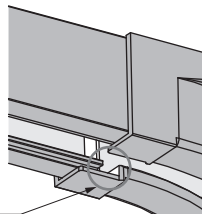

2

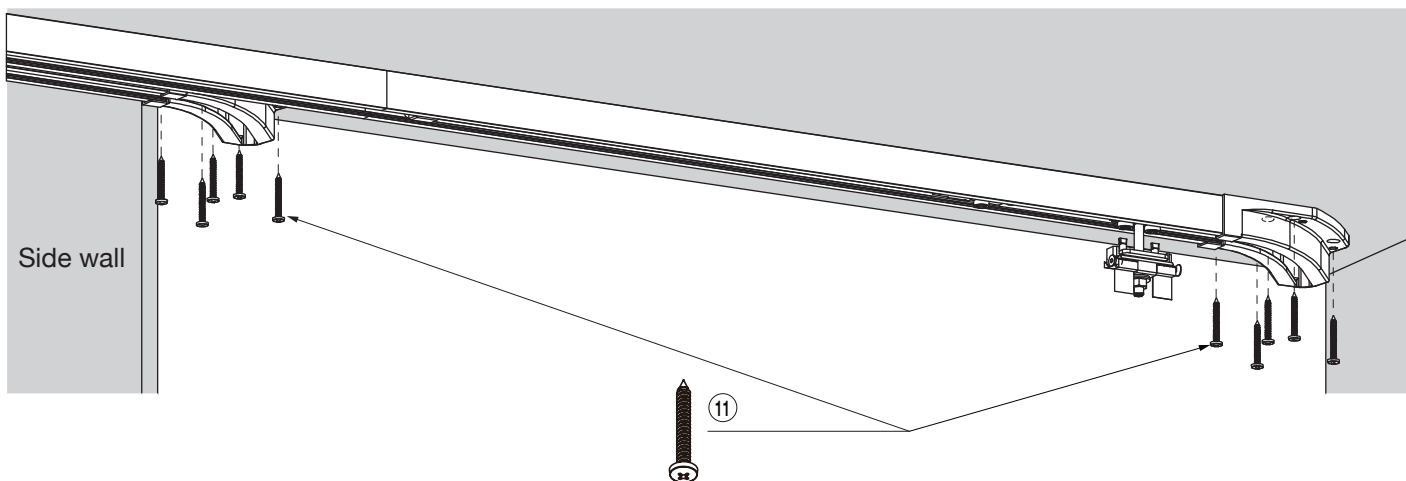

8 Inserting Upper Roller into the Upper Track A (trailing edge)

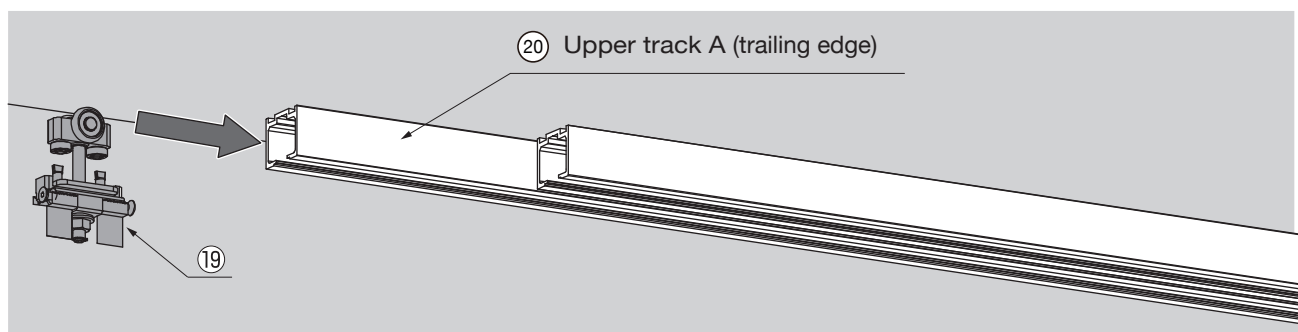

9 Mounting of the Trigger

Mount the triggers on the upper track A (leading edge) and Upper track B.

1 Assemble trigger to jig.

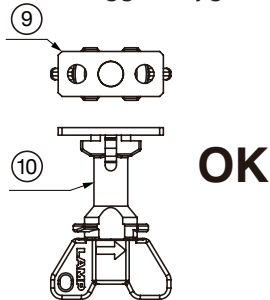

2 Align trigger with the holes.

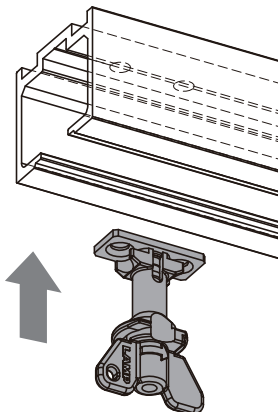

3 Turn the jig 90° and fix the trigger.

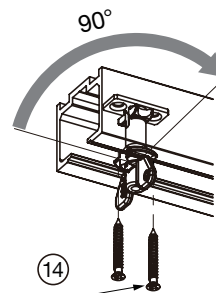

4 Remove the jig.

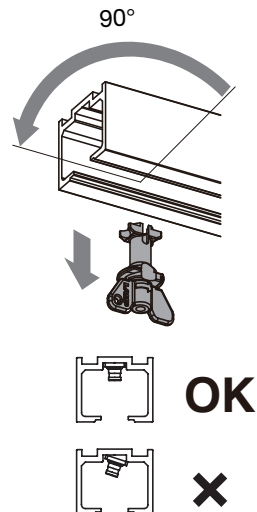

Phillips screwdriver

10 Mounting of the Bottom Guide

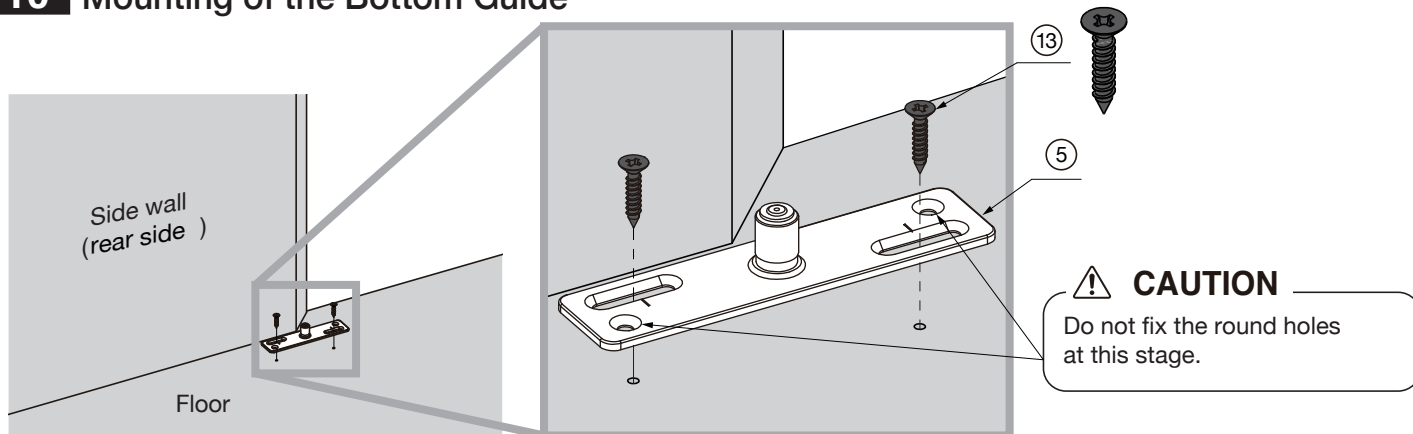

11 Hanging Door

1 Put the door on the support, then place the groove of the bottom track on the protruding part of the floor guide.

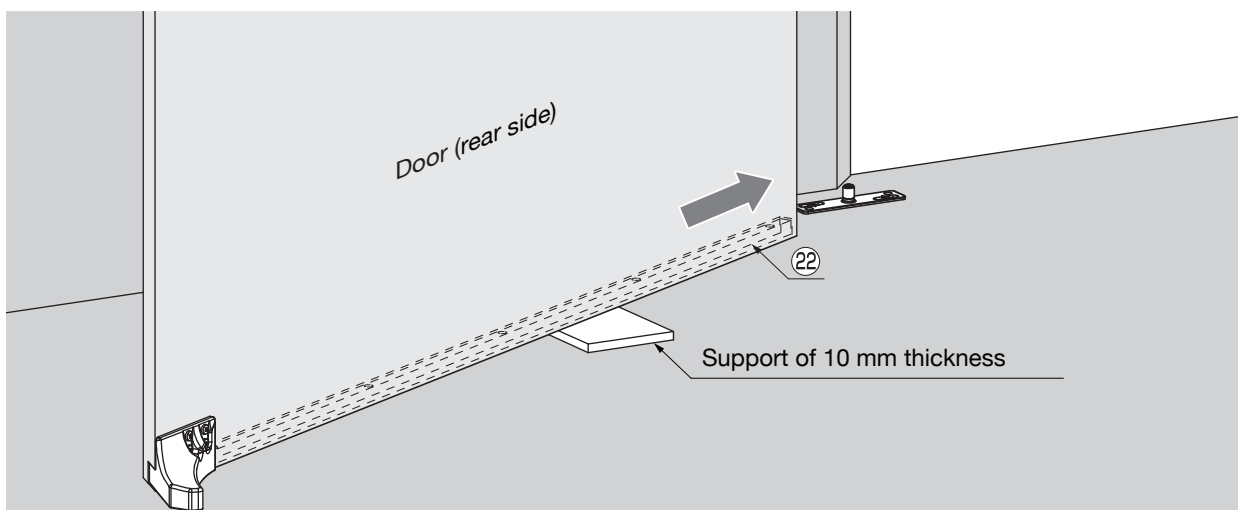

2 Slide the Soft Closer (leading edge) into the Bracket (leading edge)

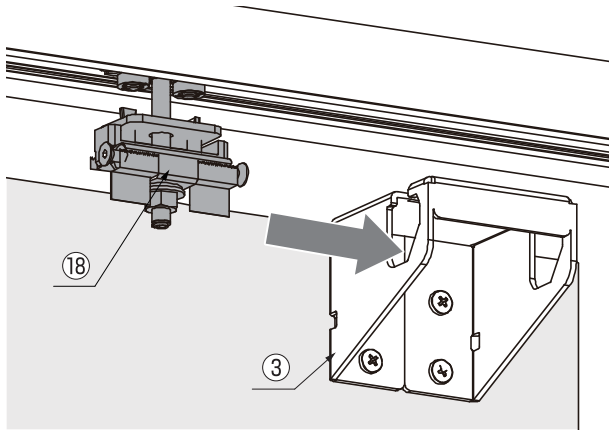

CAUTION

Do not remove the tape before inserting, since it makes the work difficult.

Slide the Soft Closer (trailing edge) into the Bracket (trailing edge)

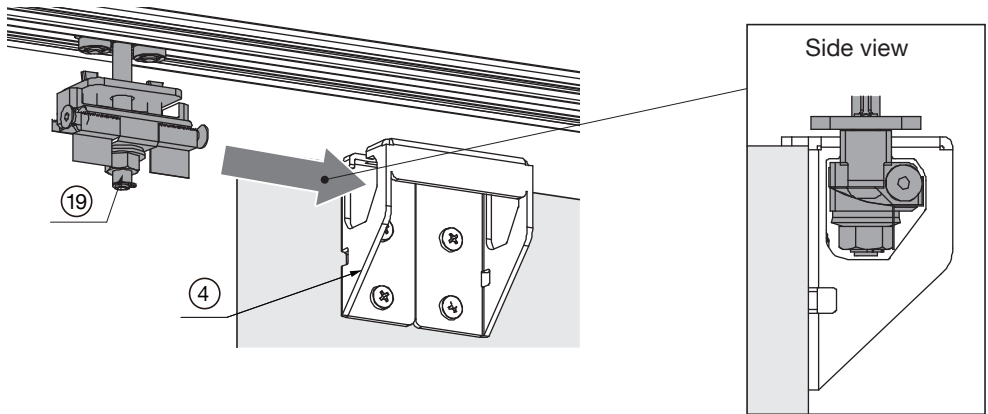

3 Hanging

The figures show the procedure for the leading edge 18. The procedure for the trailing edge 19 will be the same.

(1) Remove the tapes.

(2) Loosen the fastening nut for 360°

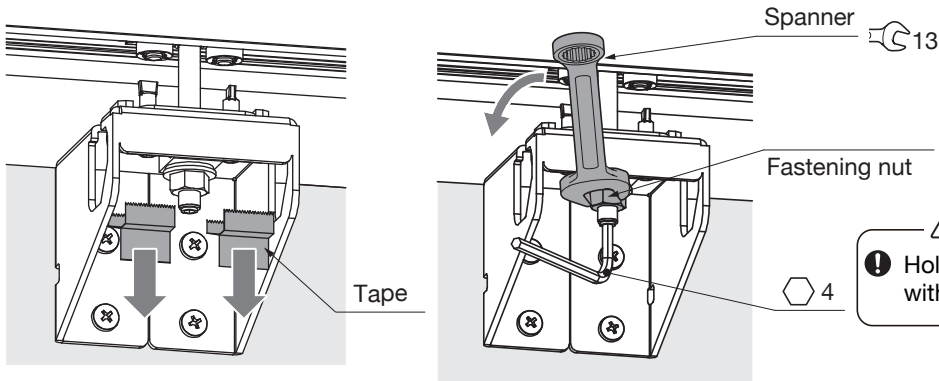

(3) Turn the screw to raise the door from the support.

(4) Tighten the fastening nut

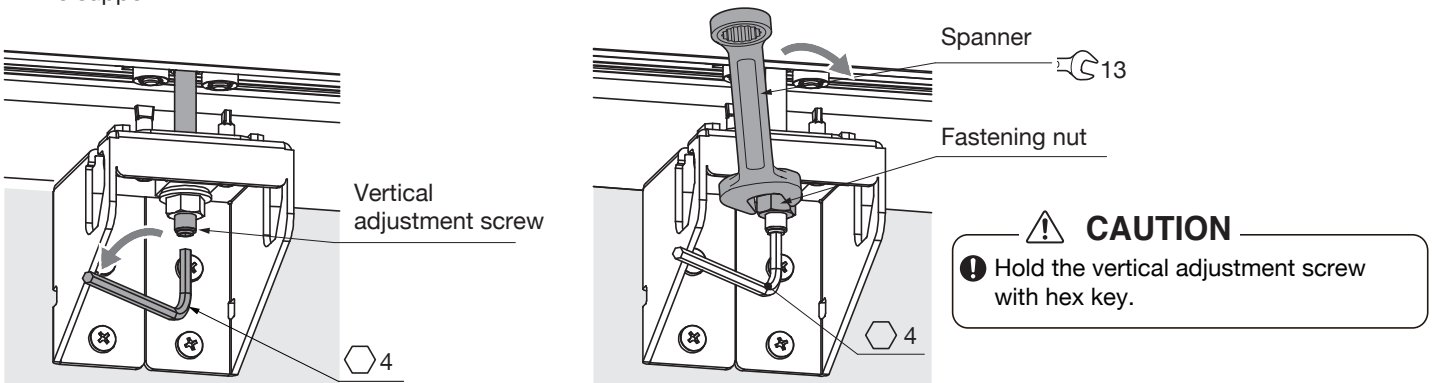

CAUTION

Hold the vertical adjustment screw with hex key.

CAUTION

Hold the vertical adjustment screw with hex key.

(5) Tighten the fastening bolt

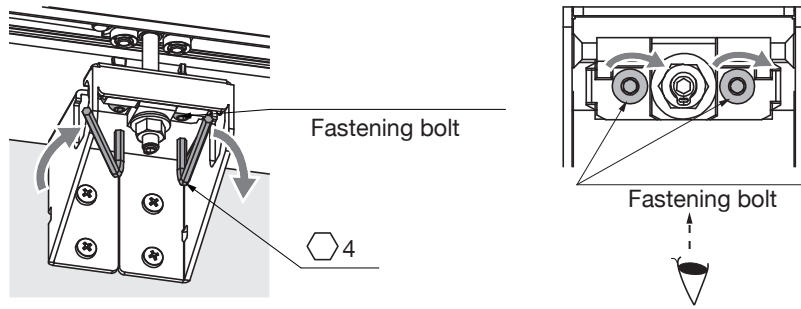

12 Door Adjustments

⚠ CAUTION

- ❗ Move door slowly so as not to go out of tune.
- ❗ Be sure to make adjustments in the orders of following procedure.
- ⚠ We recommend that the adjustment be made by two people, since the door position needs to be checked from outside.

3 Depth adjustment (Bottom of trailing edge)

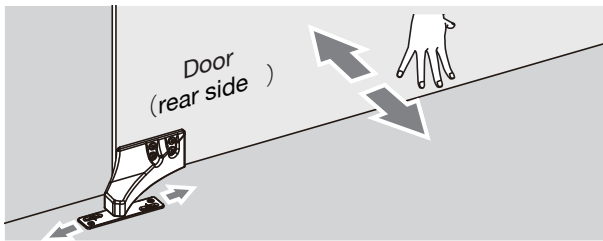

2 Depth adjustment (Leading edge)

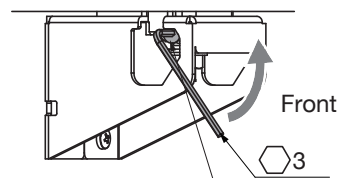

Depth adjustment screw

Back

Depth adjustment screw

4 Depth adjustment (Bottom of leading edge)

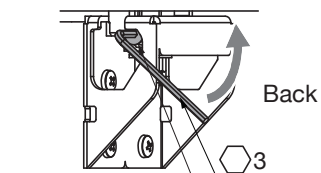

Depth adjustment screw

Front

Depth adjustment screw

1 Vertical adjustment

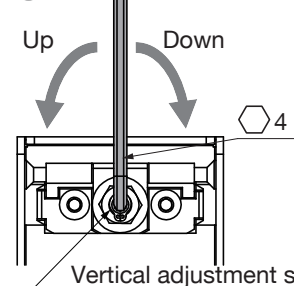

Vertical adjustment screw

1 Vertical adjustment

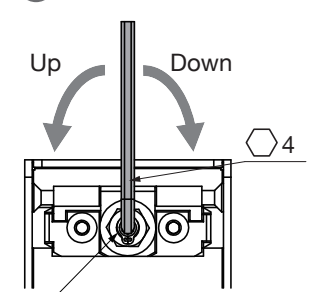

Vertical adjustment screw

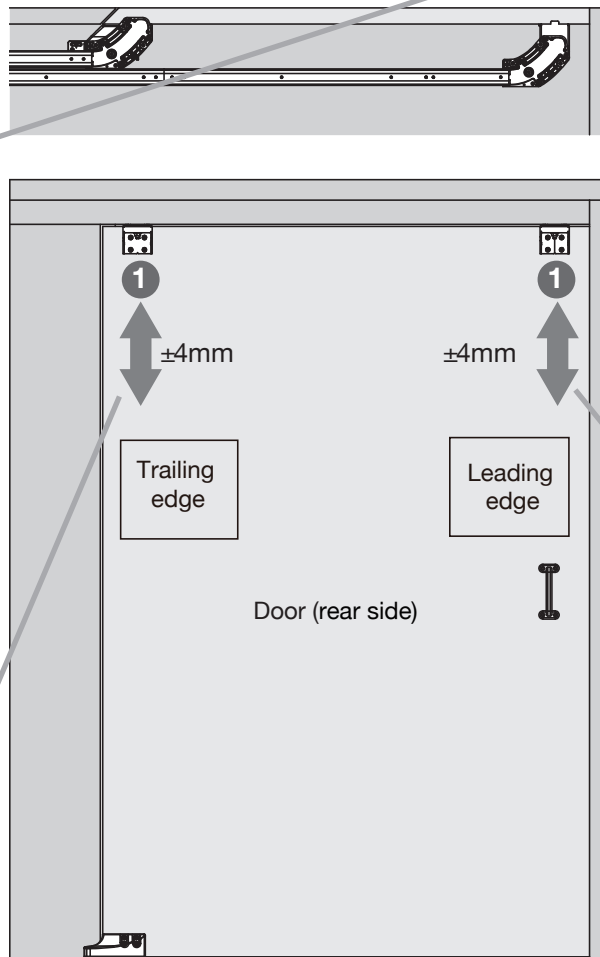

■ Preparations for adjustments

The below figures show the bracket for the leading edge.
The procedure for the trailing edge will be the same.

(1) Loosen the fastening nut for 360°.

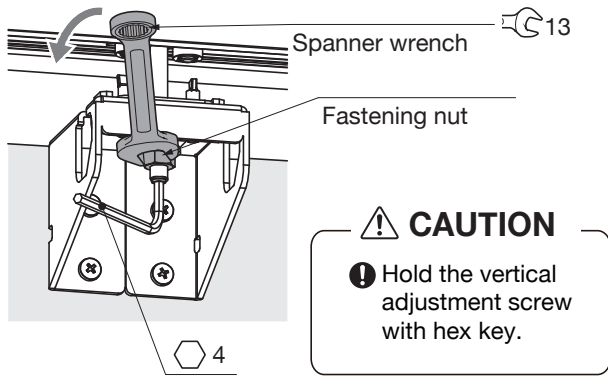

(2) Loosen the fastening bolts for 360°.

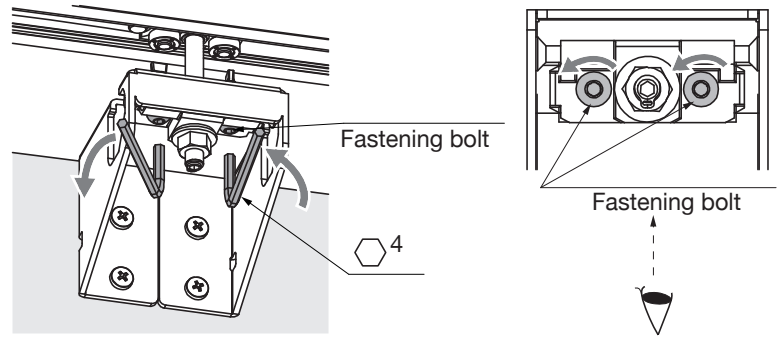

■ Adjustments procedure

1 Vertical adjustment

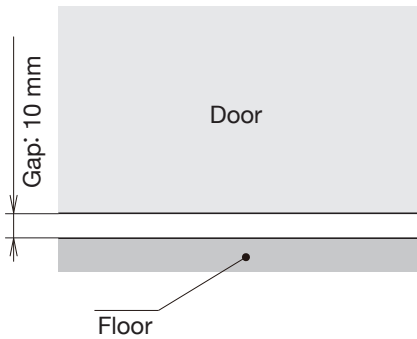

CAUTION

The top end and the bottom end of the door should reach the vertical frame in the same time.

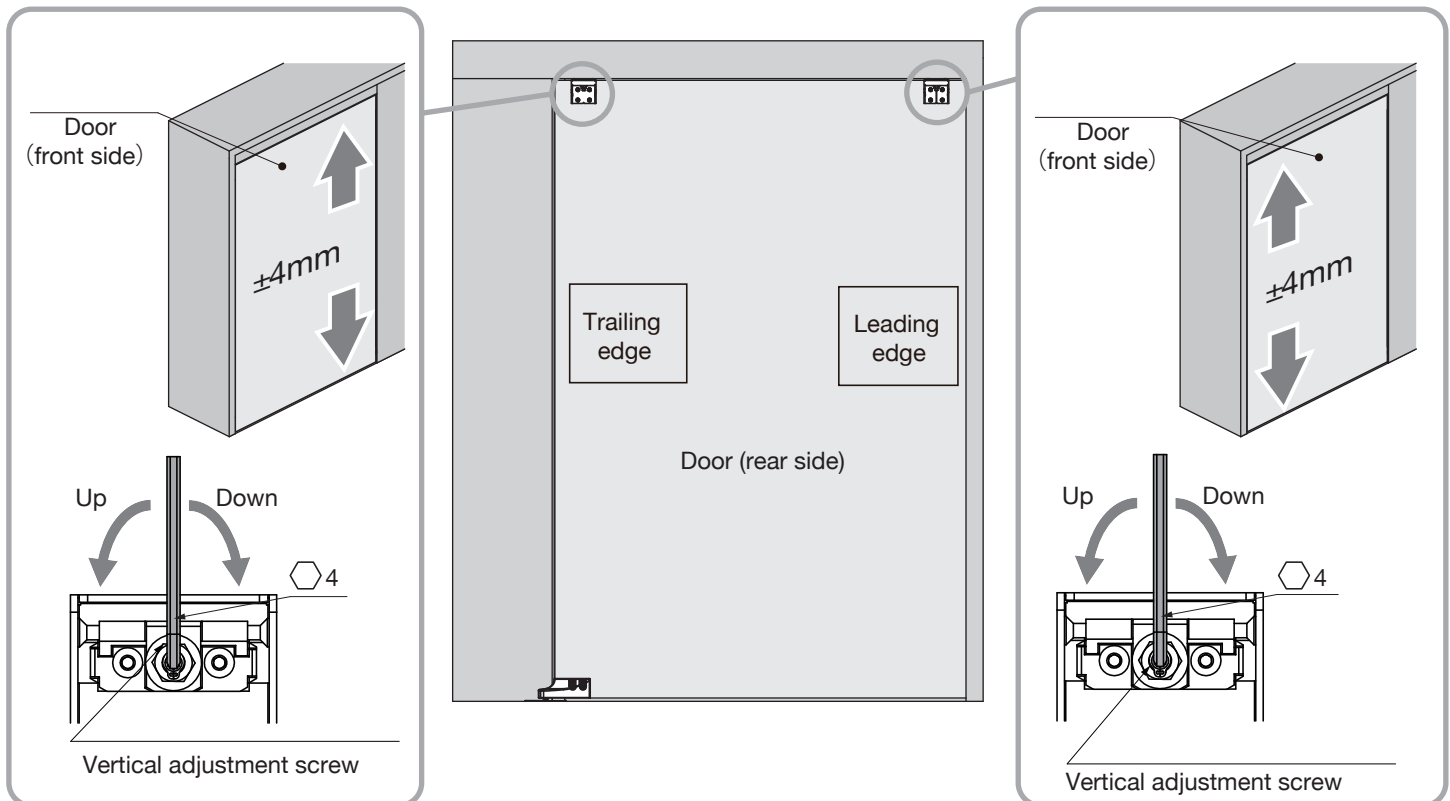
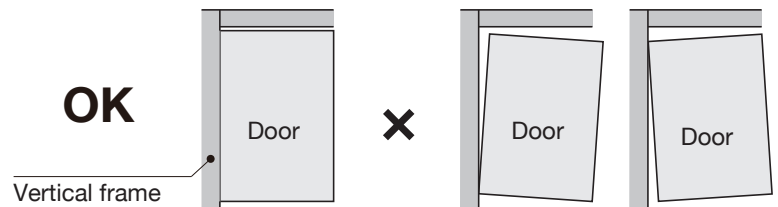

2 Depth adjustment (Top of leading edge)

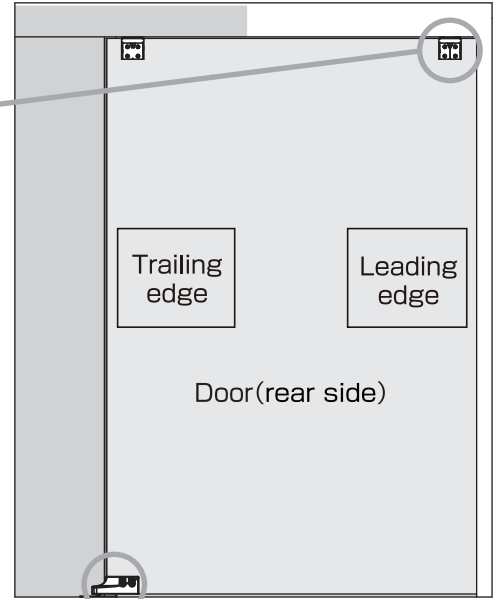
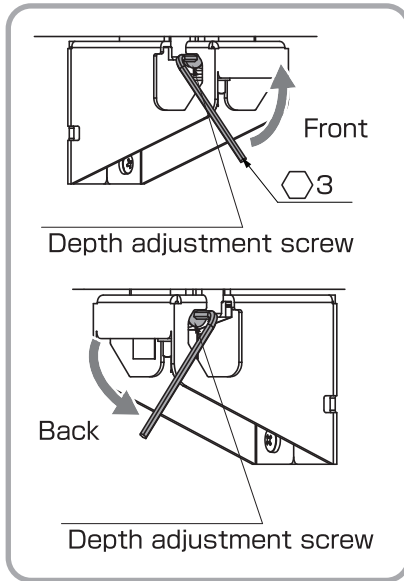
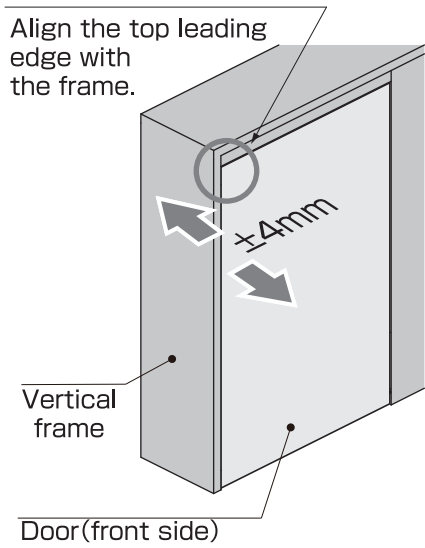

3 Depth adjustment (Bottom of trailing edge)

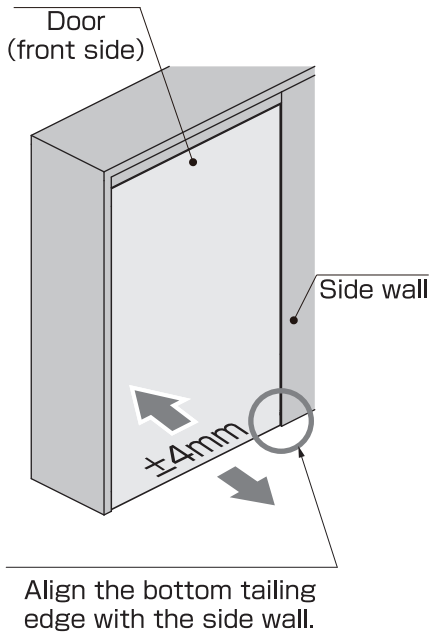

(1) Loosen the screws.

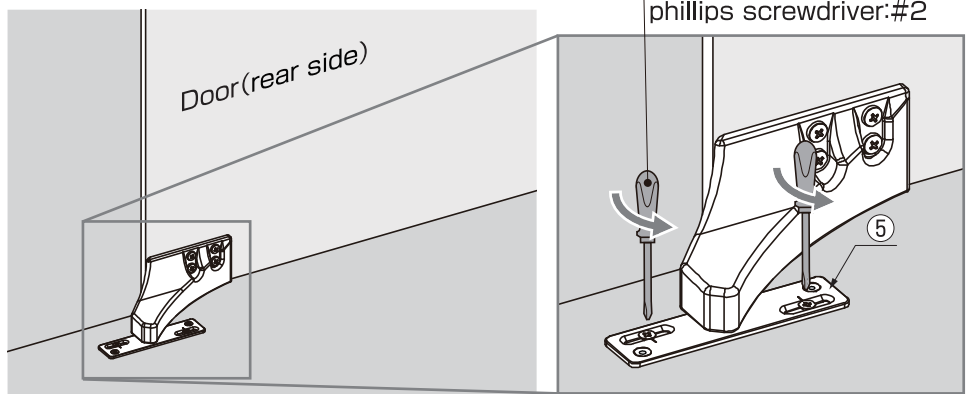

(2) Push the door and make it flash with the side wall.

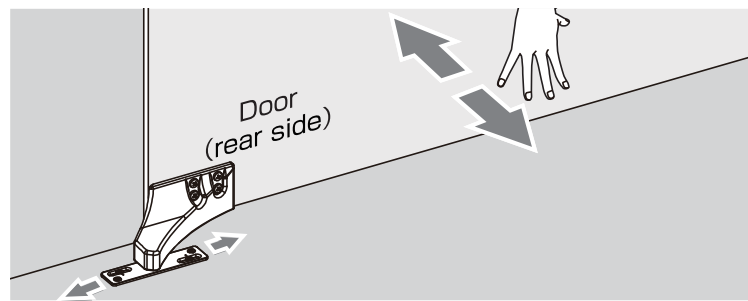

(3) Tighten the screws.

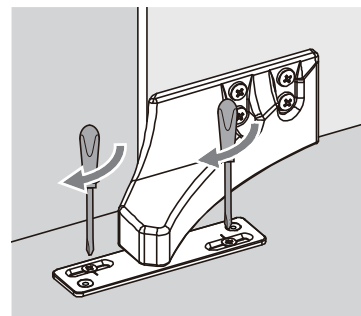

(4) Fasten the rest two holes with screws.

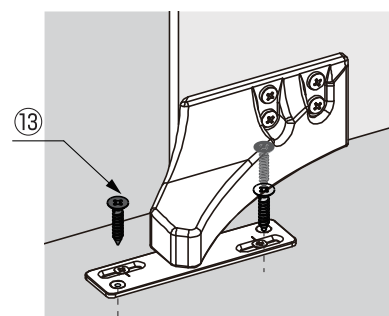

4 Depth adjustment (Bottom of leading edge)

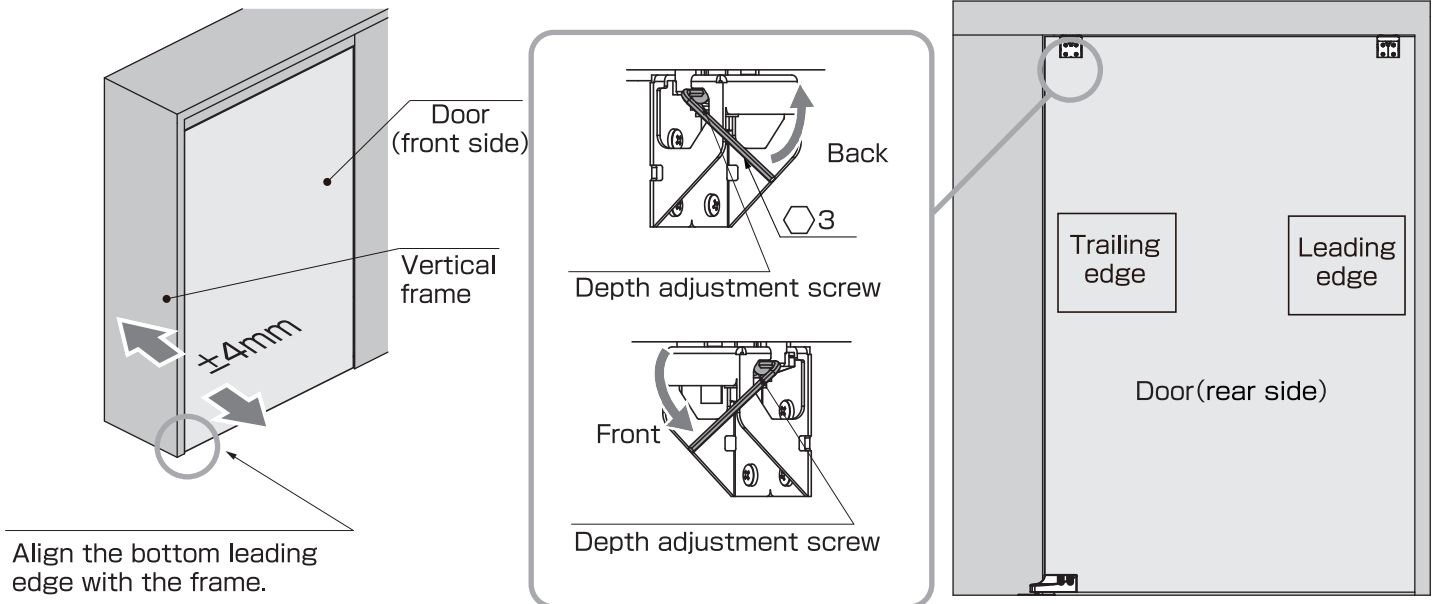

Align the bottom leading edge with the frame.

※4 If the adjustment cannot be done completely, check if the door is warped, or check the parts mounting positions are correct.

5 Tighten the fastening nut after the adjustment.

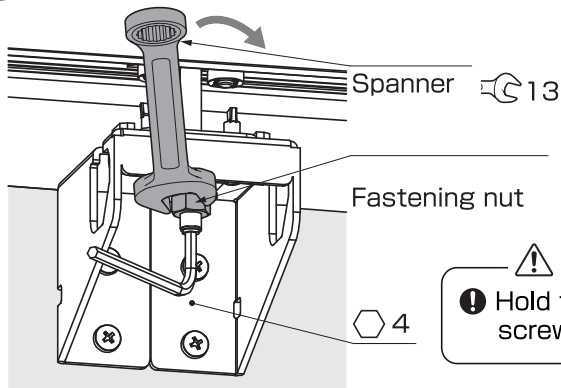

CAUTION
 Hold the vertical adjustment screw with allen key.

6 Tighten the fastening bolts.

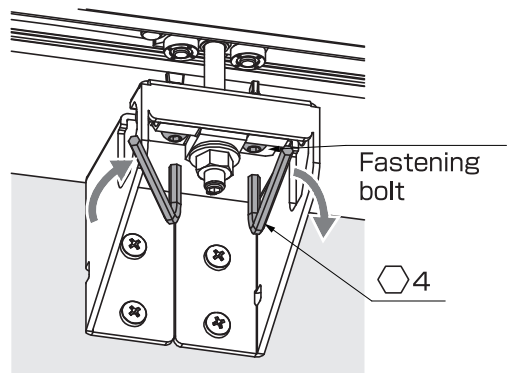

7 Press the heads of Depth adjustment screws to the bracket (3)(4).

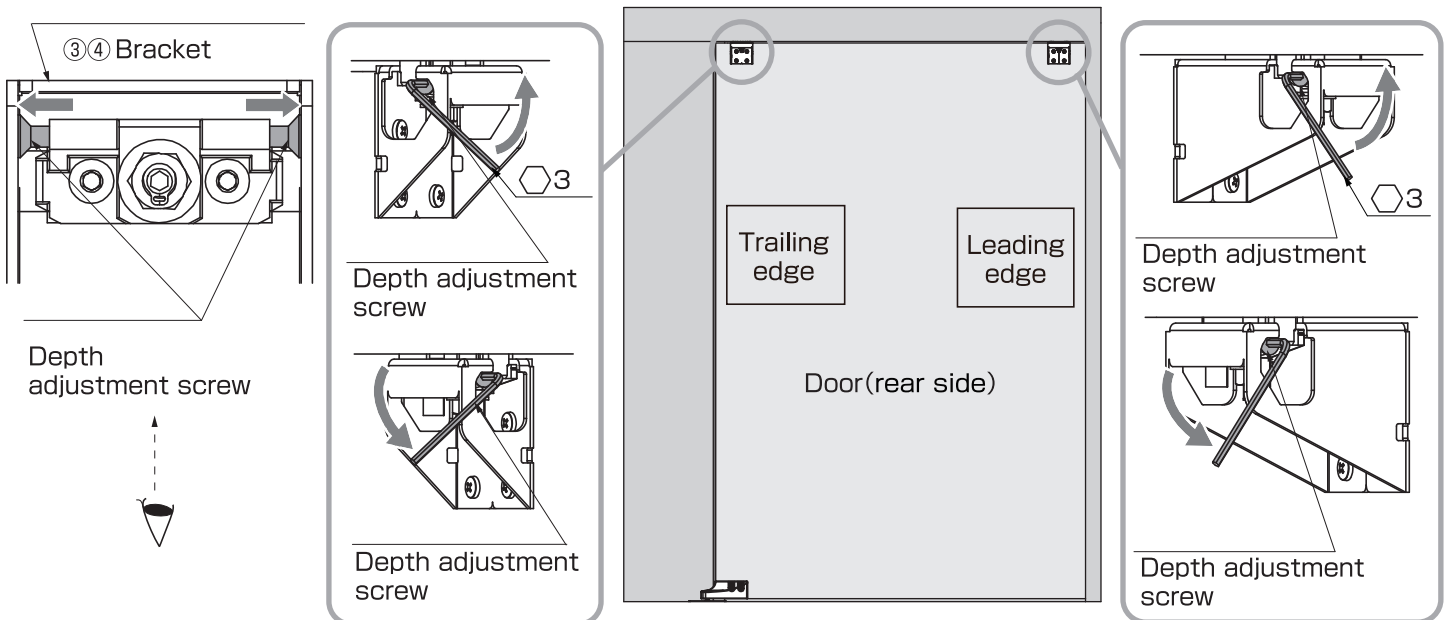

8 Check the door movement, then check if there's any screw or nut loosened.

13 Mounting of Door Stopper (Floor)

⑦ Door stopper (floor)

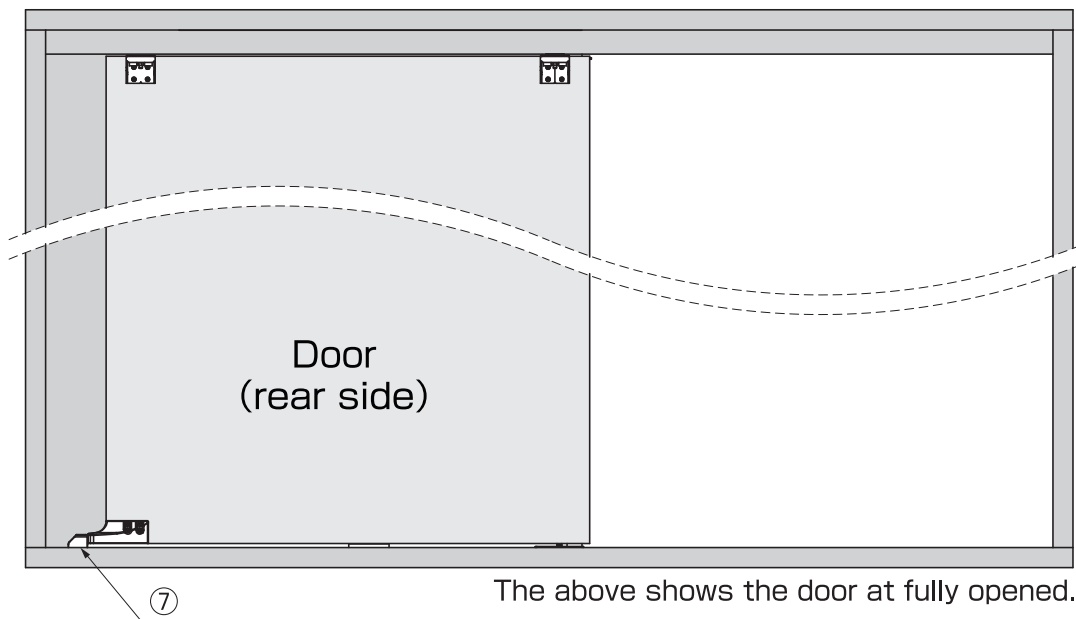
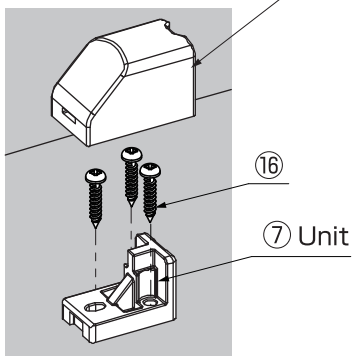

14 Fastening of Bumper Block

① Loosen the screw, then insert the bumper block into the upper track A (trailing edge).

② Slide the bumper block until it touches the door roller.

③ Fasten the screw.

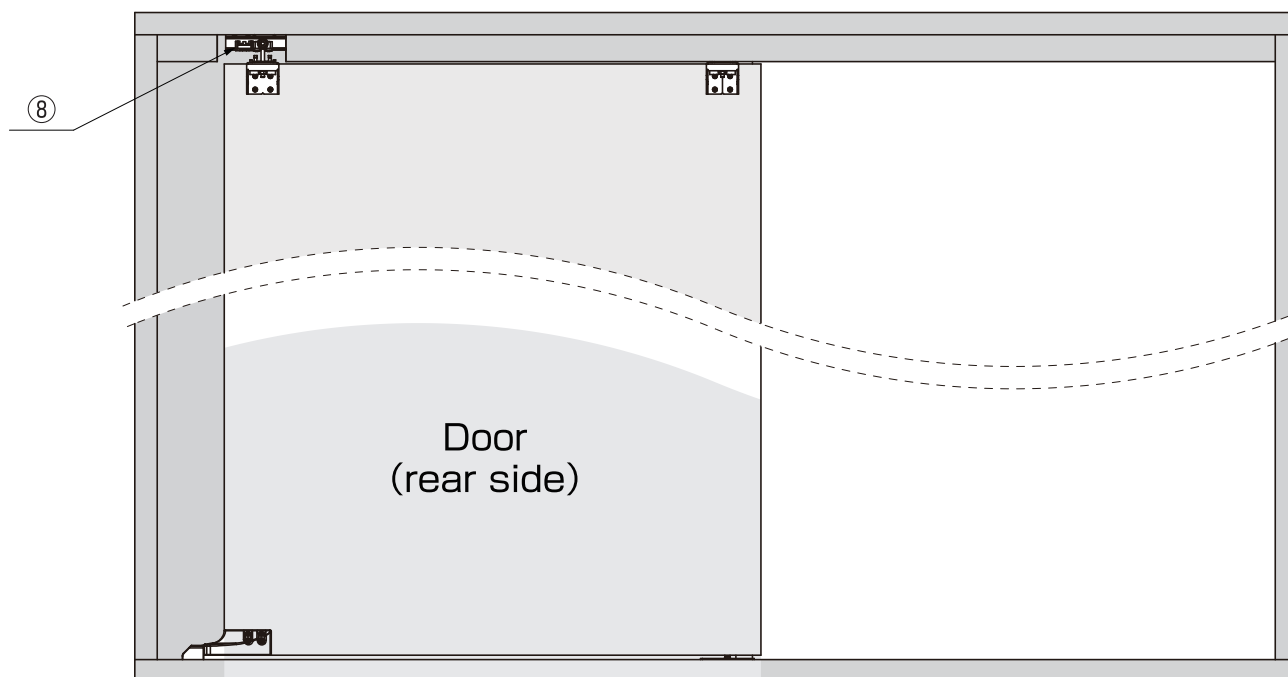
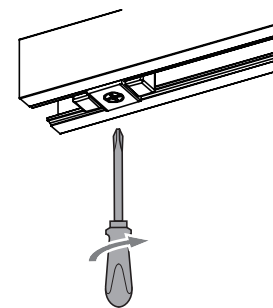
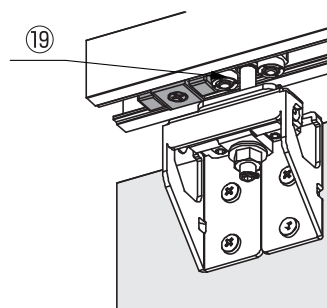
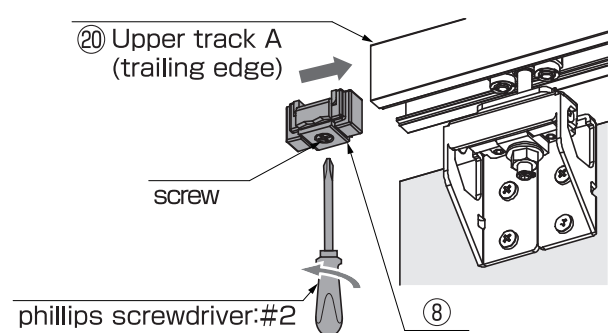

The above shows the door at fully opened.

15 Pasting the Caution Sticker

Paste the caution sticker to a prominent place on the door.

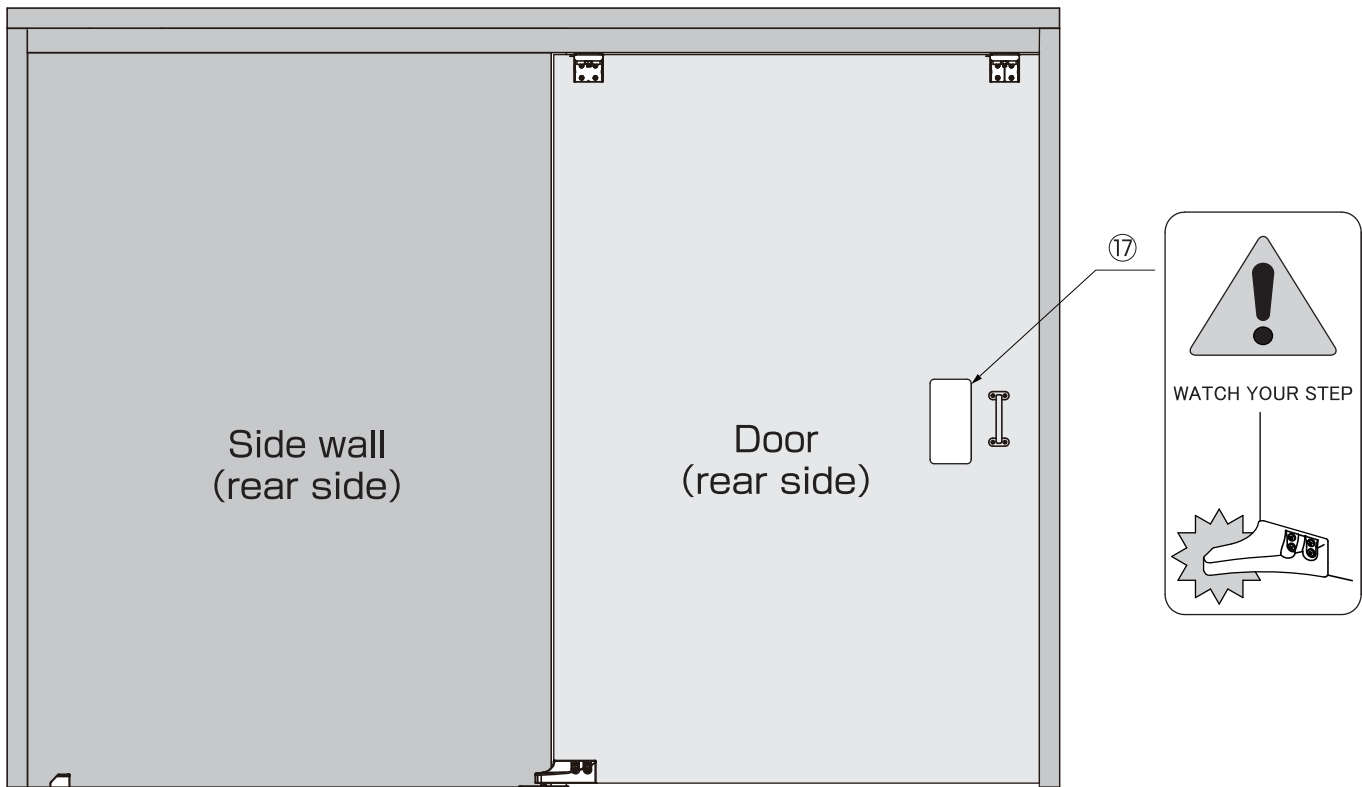

Final verification	Verify that all screws are securely tightened, and verify that all screws have been used.
--------------------	---

PERIODICAL INSPECTION	<ul style="list-style-type: none">• Clean inside of track.• Check upper and lower gaps between the door and frame. If necessary, adjust the gaps.
-----------------------	--

■ TROUBLE SHOOTING

Trouble	Checkpoint	Solution
Door stops during soft closing	Check if door bottom contacts the floor or bottom track contacts the floor guide.	Verify that the track mounting screws are not loosened. Then, adjust the door height such that the clearance between the door bottom and floor is 10 mm (Ref. to section 12 ①).
	Check if the room where the track installed is a closed chamber.	Install a ventilator to relieve the air.
	Check if the upper track or guiding track (top) are set horizontally.	Using a level gauge, reset the upper track and guiding track horizontally.
	Check if door touches the side wall.	Adjust the door depth position to backward (Ref. to section 12 ③).
No soft closing	Check if trigger is installed.	Install trigger to correct position.
	Check if door is closed or opened by excessive force.	Do not close or open the door by excessive force as it may damage the soft closer.
	The position of the trigger catcher may become dislocated. (It is hidden as installed in upper track.)	Remove the door and the upper track, then check the status of the trigger catcher in section 4 .
Abnormal noise during operation	Check if door bottom contacts the floor or bottom track contacts the floor guide.	Verify that the track mounting screws are not loosened. Then, adjust the door height such that the clearance between the door bottom and floor is 10 mm (Ref. to section 12 ①).
	Check track rollers for aluminum dust.	Remove the track, then pull out and clean the rollers and track.
	Check if door is warped.	If the door is warped, use anti-warping fitting or replace the door.
	Check if door touches the side wall.	Adjust the door depth position to backward (Ref. to section 12 ③).
	Check if the fastening screws are loosened.	Fasten the screws.
	Check the tracks if there's any gap or unevenness at the jointed parts.	Re-mount the tracks not to leave any gap nor unevenness at the jointed parts.
Heavy door operation	Check if door bottom contacts the floor or bottom track contacts the floor guide.	Verify that the track mounting screws are not loosened. Then, adjust the door height such that the clearance between the door bottom and floor is 10 mm (Ref. to section 12 ①).
	Check if door is warped.	If the door is warped, use anti-warping fitting or replace the door.
	Check if door touches the side wall.	Adjust the door depth position to backward (Ref. to section 12 ③).
Door does not move	Check if the fastening screws are loosened.	Fasten the screws.
Door starts to move	Check if the upper track is set horizontally.	Using a level gauge, reset the upper track horizontally.
Door stops or is caught during operation	Check the tracks if there's any gap or unevenness at the jointed parts.	Re-mount the tracks not to leave any gap nor unevenness at the jointed parts.
Door cannot be opened fully	Are there any obstacles in contact with the guiding track (bottom)?	Remove the obstacles.



Chicago Showroom
121 West Wacker Drive,
Chicago, IL 60601
www.sugatsune.com

